

Onfine

Socky pod lupou: Svět sociálních sítí očima mladých

 Kamila Uvírová

 Matěj Vaculčík

 Oliver Staniek

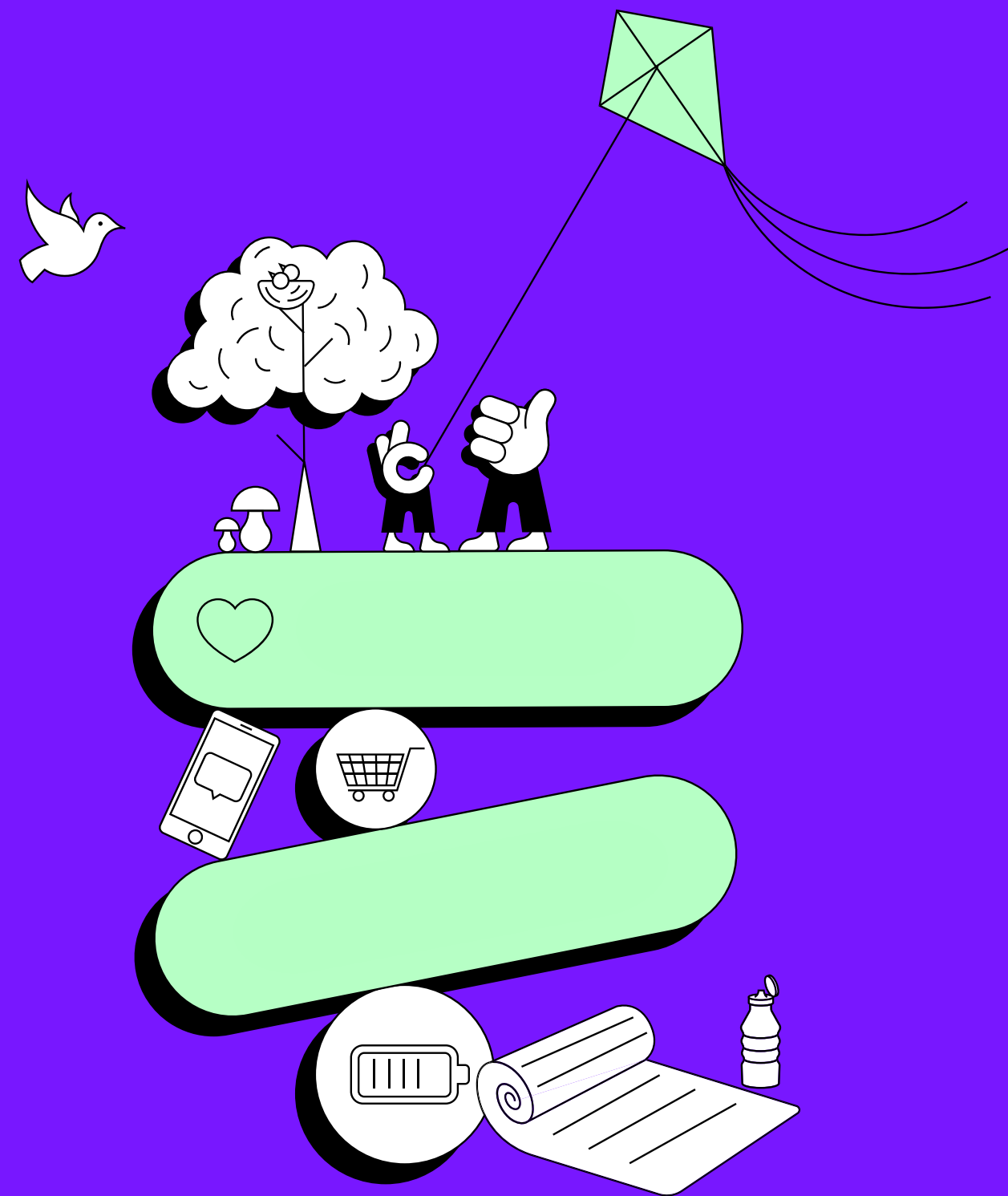

Onfine

- základní školy
- střední školy
- rodiče
- vyučující
- ambasadorstvo
- firmy
- příměstské tábory



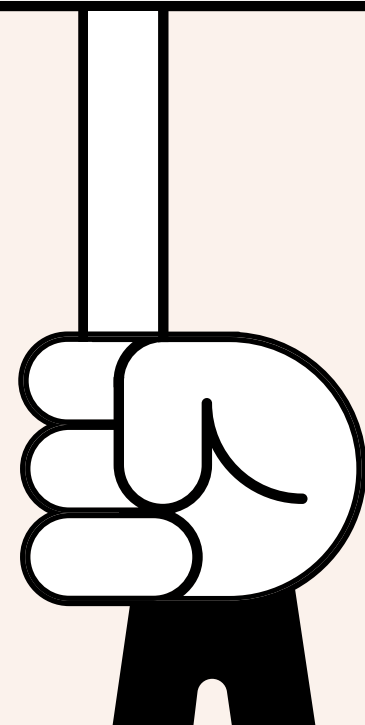
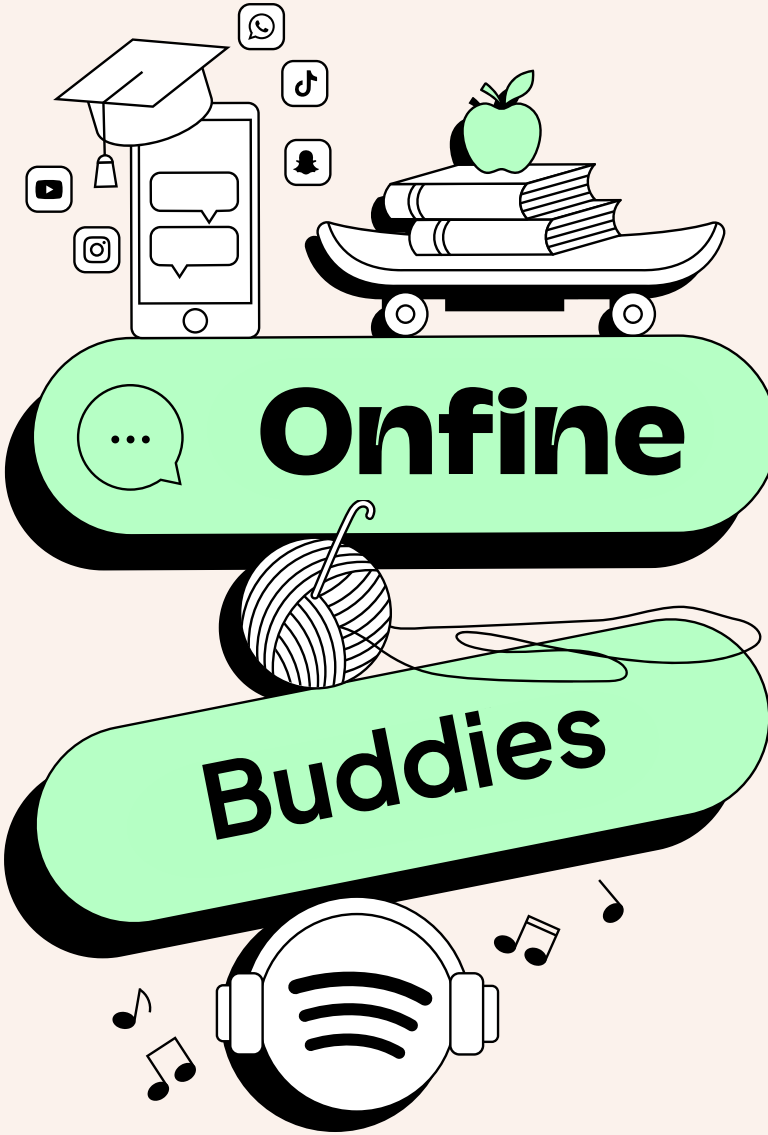
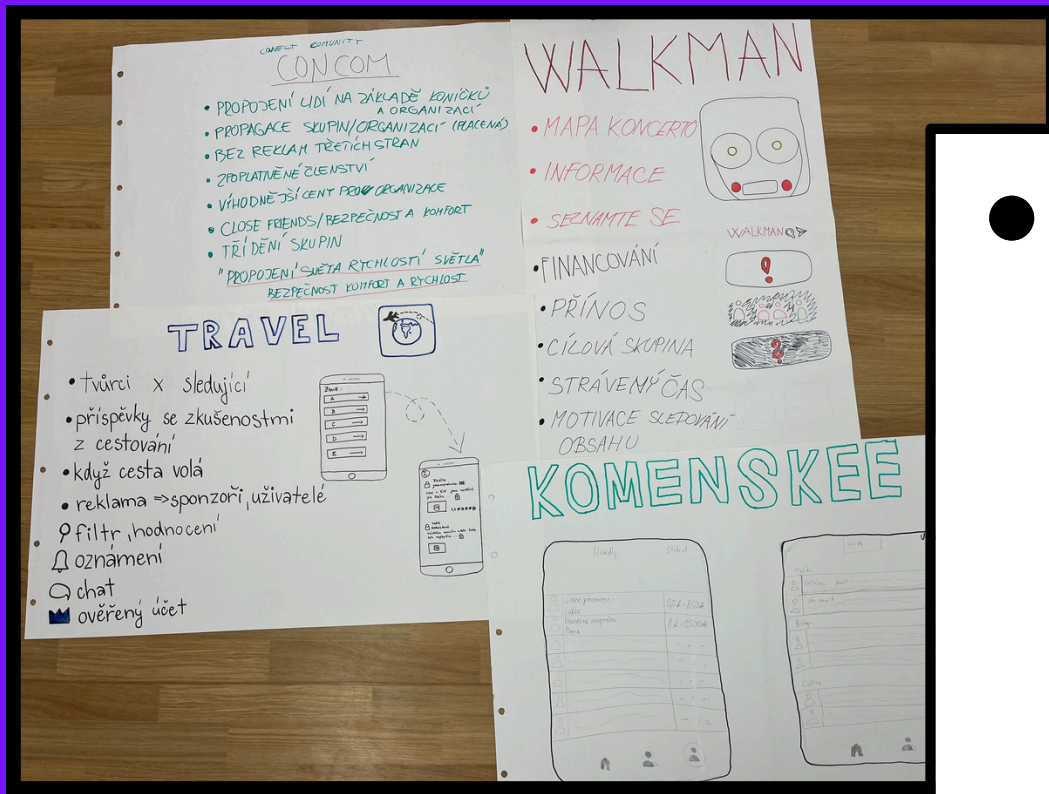

Onfine

Proč právě tento
workshop?

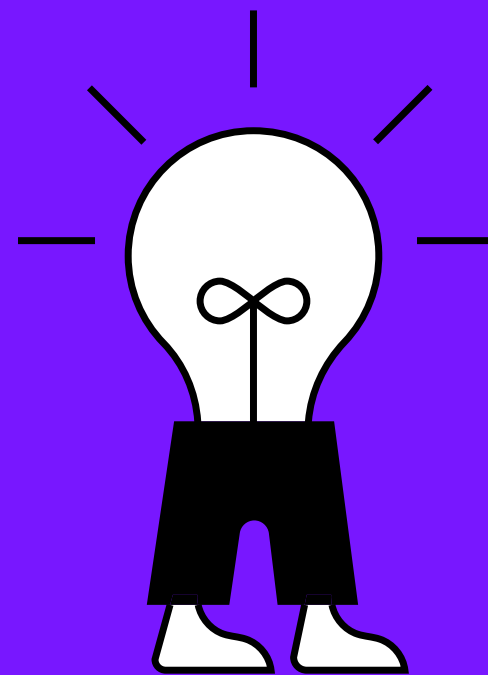

Online

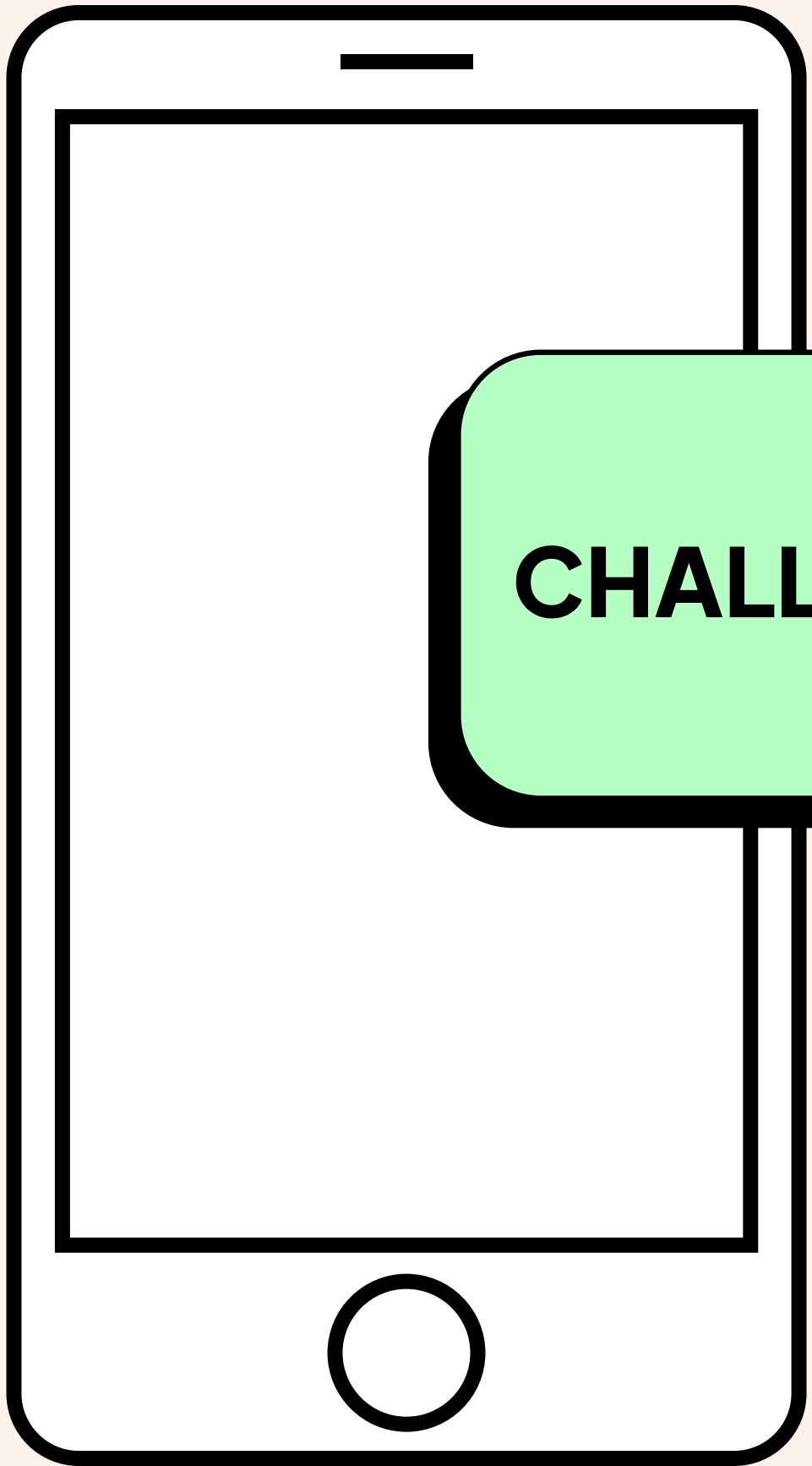

CHALLENGE!

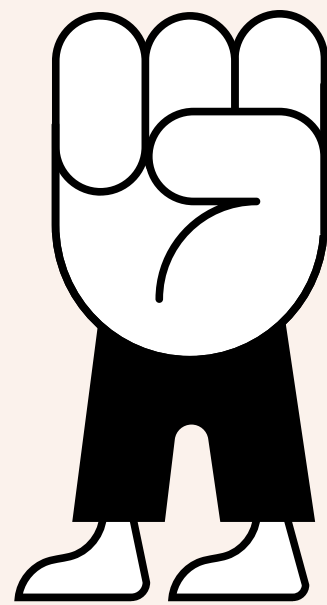

Online

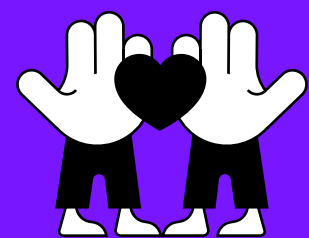

1

ÚVOD



2

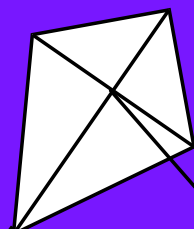

3

ZNÁTE
VŠECHNY
SOCKY?

4



PONOR
DO SVĚTA
SOCIÁLNÍCH SÍTÍ

JAK NA ZDRAVÉ
UŽÍVÁNÍ

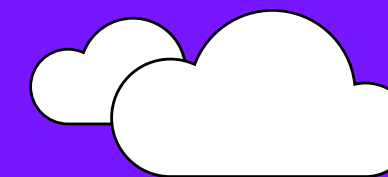

Onfine

80 %

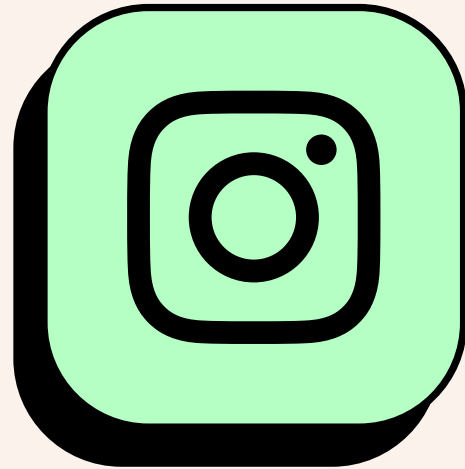

79 %



71 %



65 %



54 %



*data z Digitální
výchovy (jaro 2023)

Online

návykovost designu

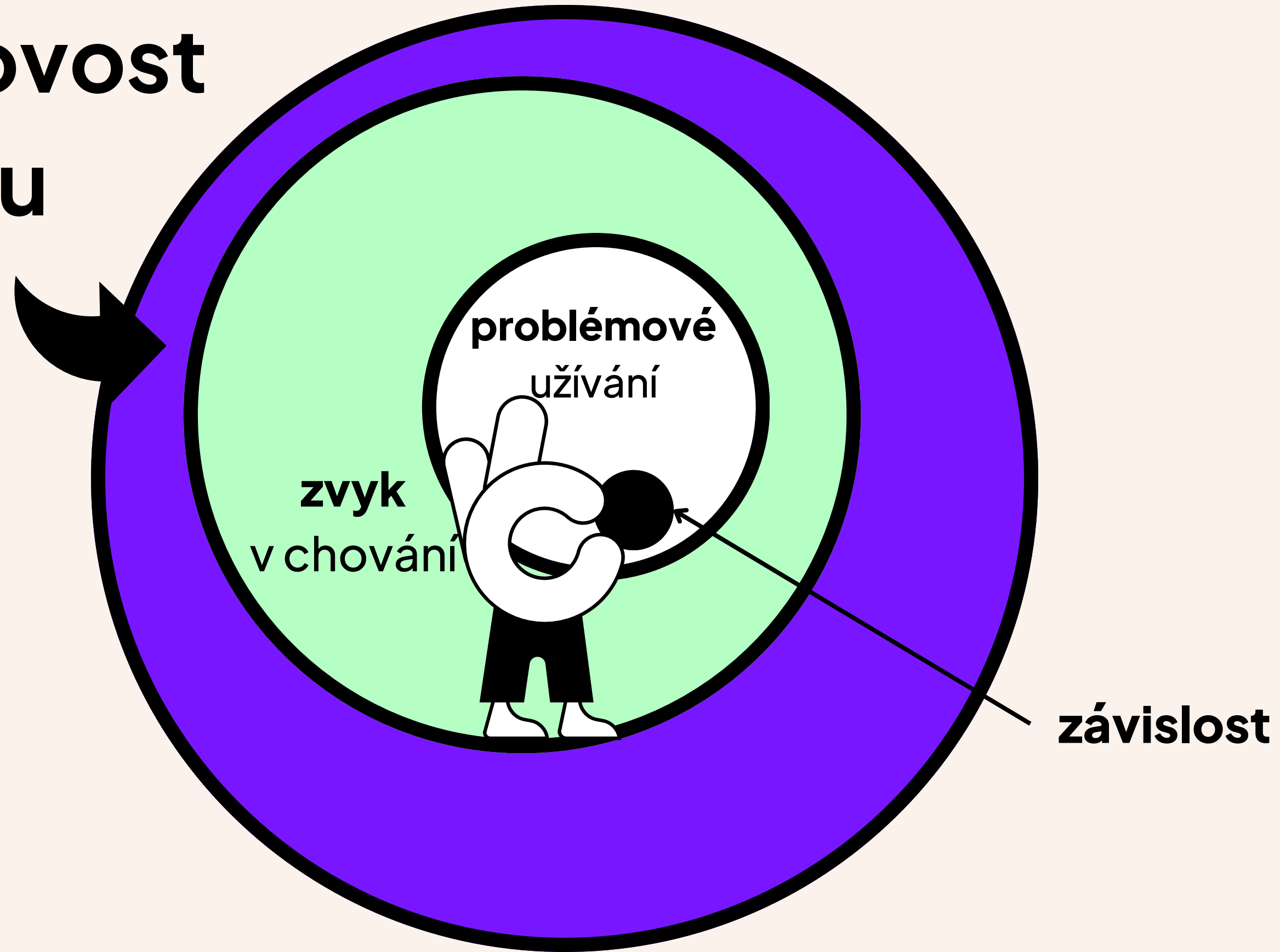

Onfine

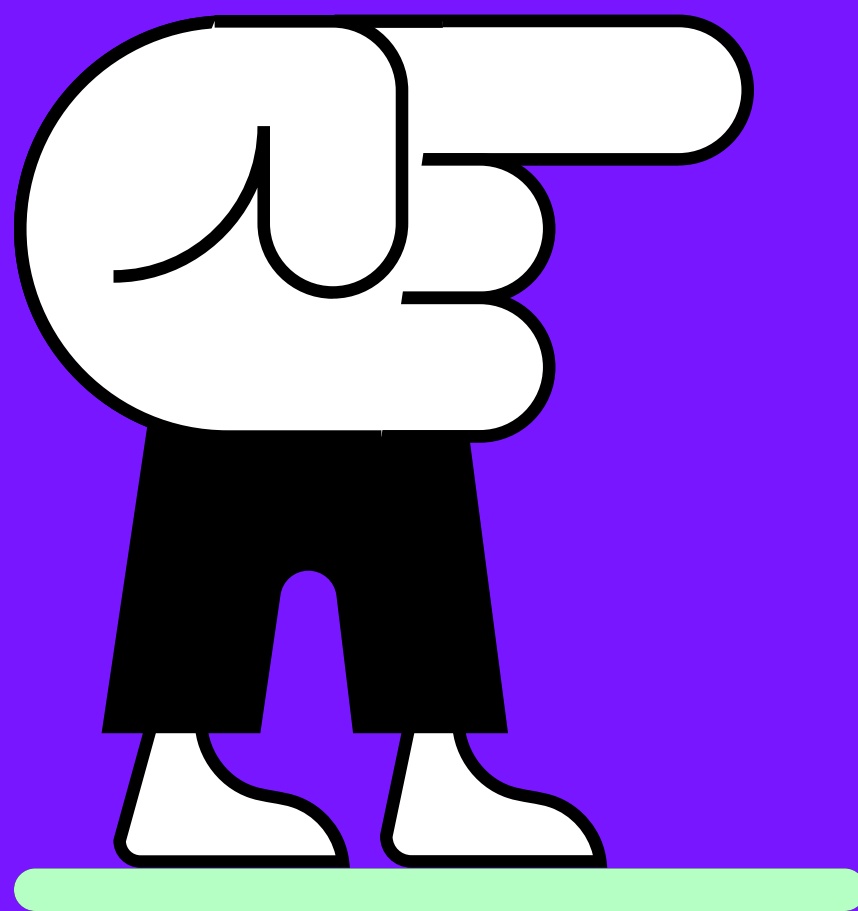

pocit **kompetence**

pocit **autonomie**

spojení s kamarády

někam patřím

psychická **pohoda**

relax

zábava

kvalitní společný čas s rodinou a kamarády

snadnější **komunikace**

možnosti **sdílení, spolupráce, inspirace**

vzdělávání, rozvoj znalostní a dovedností, **přístup k informacím**

rozšíření úhlu pohledu, **respekt k odlišnostem**

normalizace svého prožívání i vzhledu

podpora

flexibilita

V čem vnímáte že je to
pro **mladistvé**
pozitivní/přínosem?

Onfine

Ajak to máte s užívaním
sociálných sítí vy?

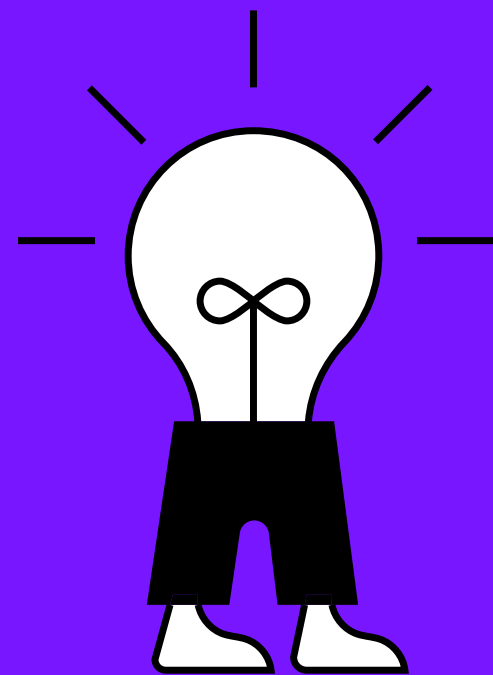

Online

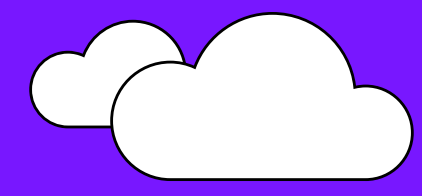

ÚVOD

ZNÁTE
VŠECHNY
SOCKY?

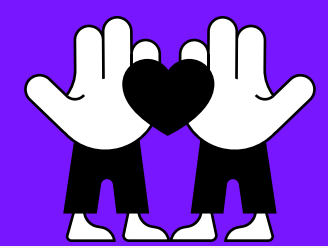

1

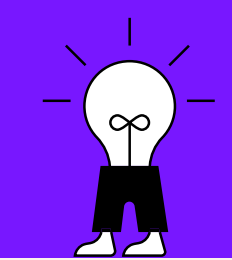

2



3

4



PONOR
DO SVĚTA
SOCIÁLNÍCH SÍTÍ

JAK NA ZDRAVÉ
UŽÍVÁNÍ

Onfine



Facebook



Messenger



Facebook

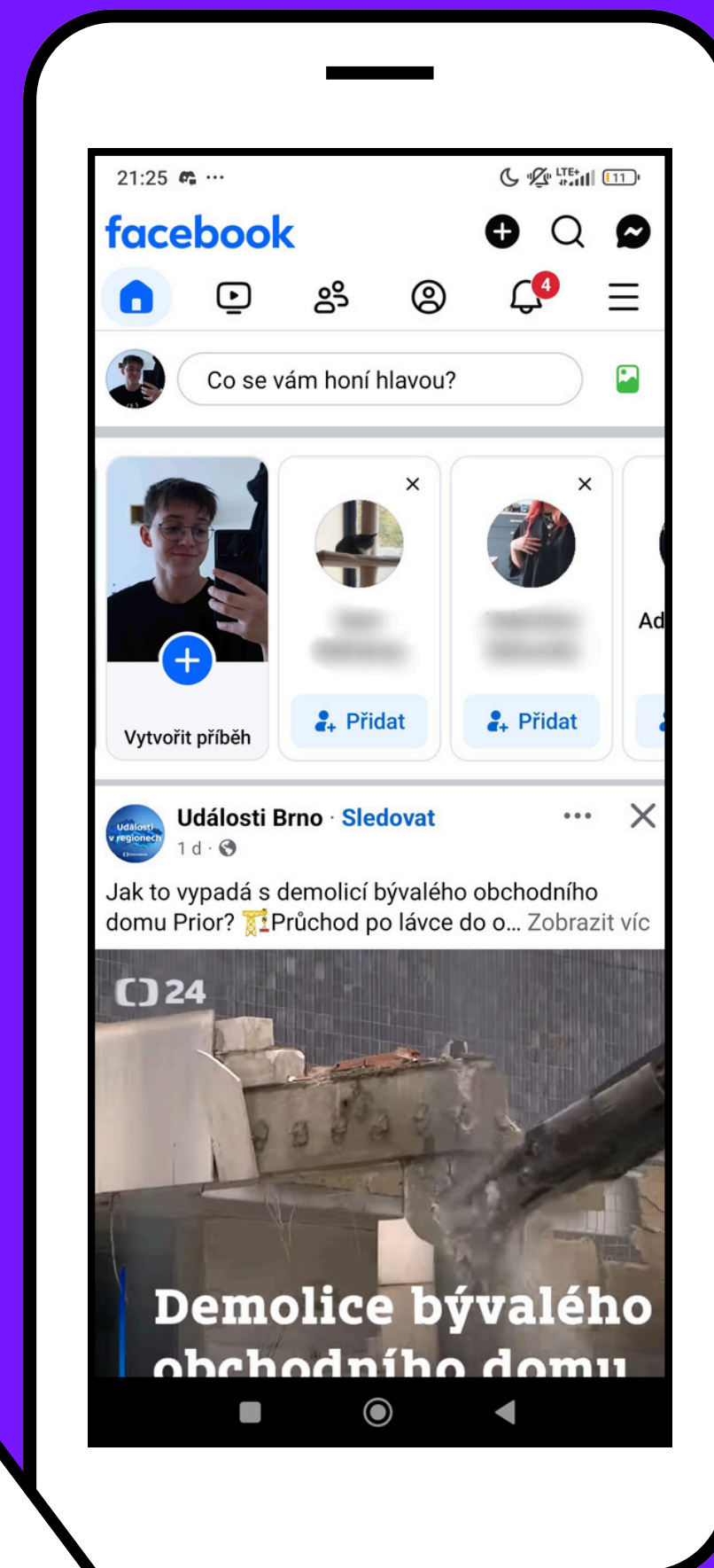
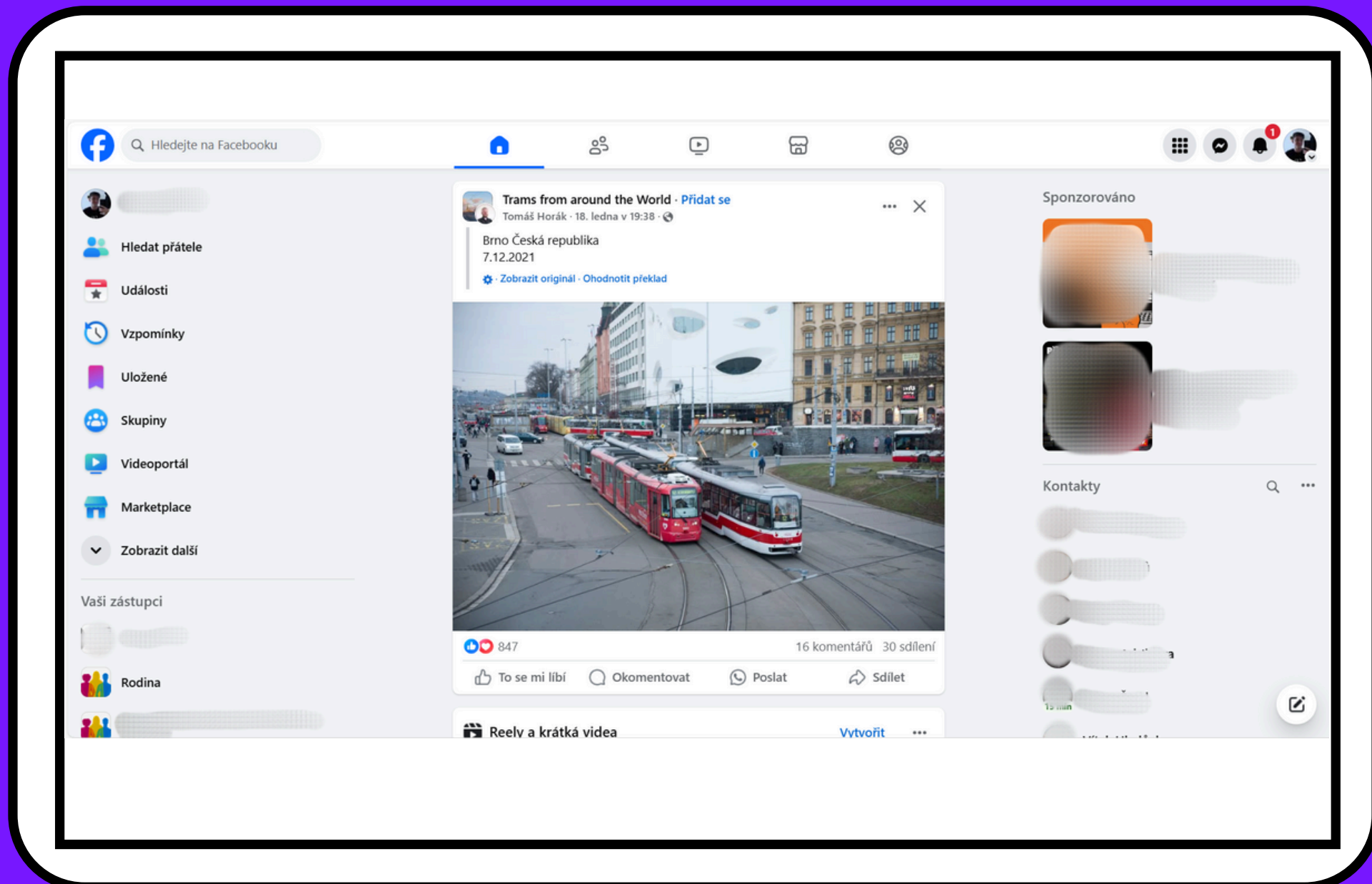

Onfine



Facebook

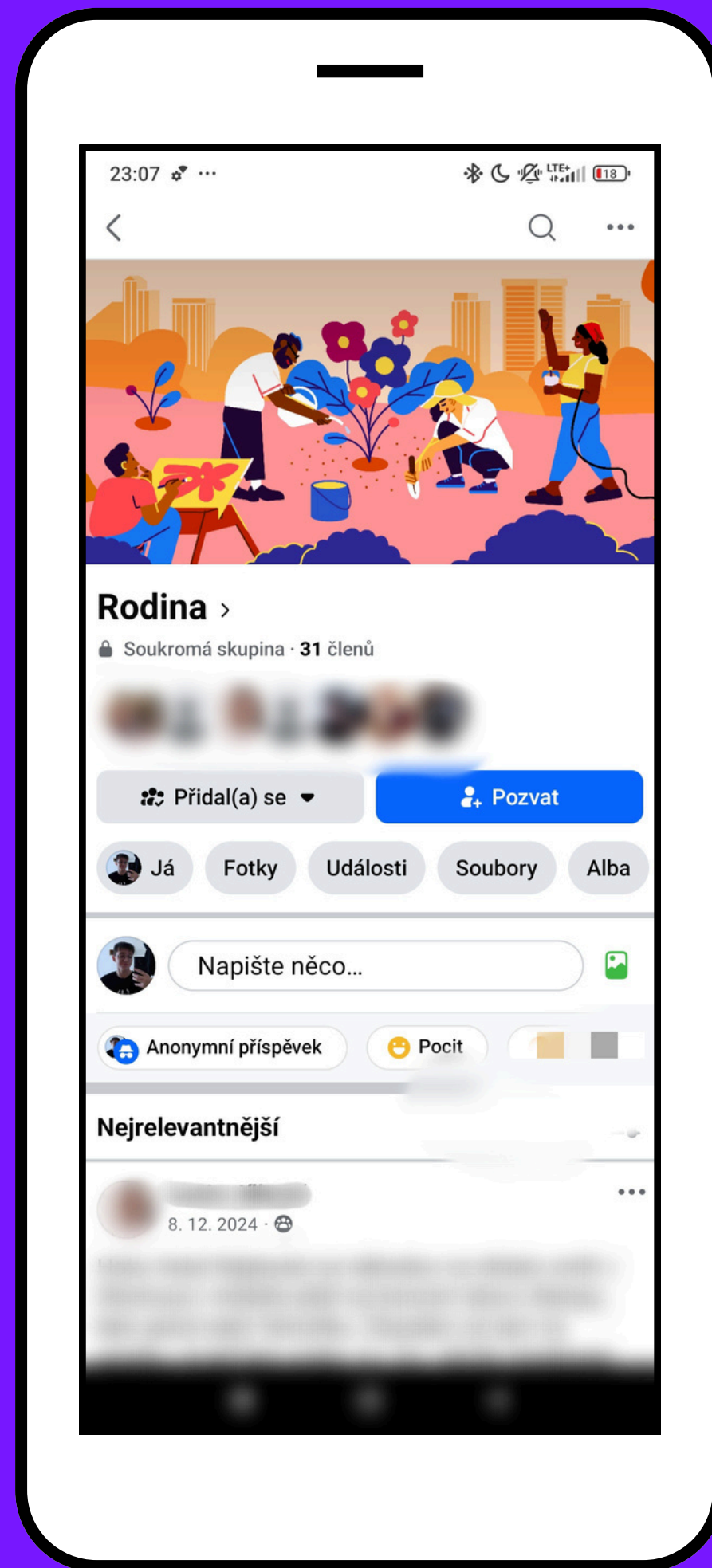
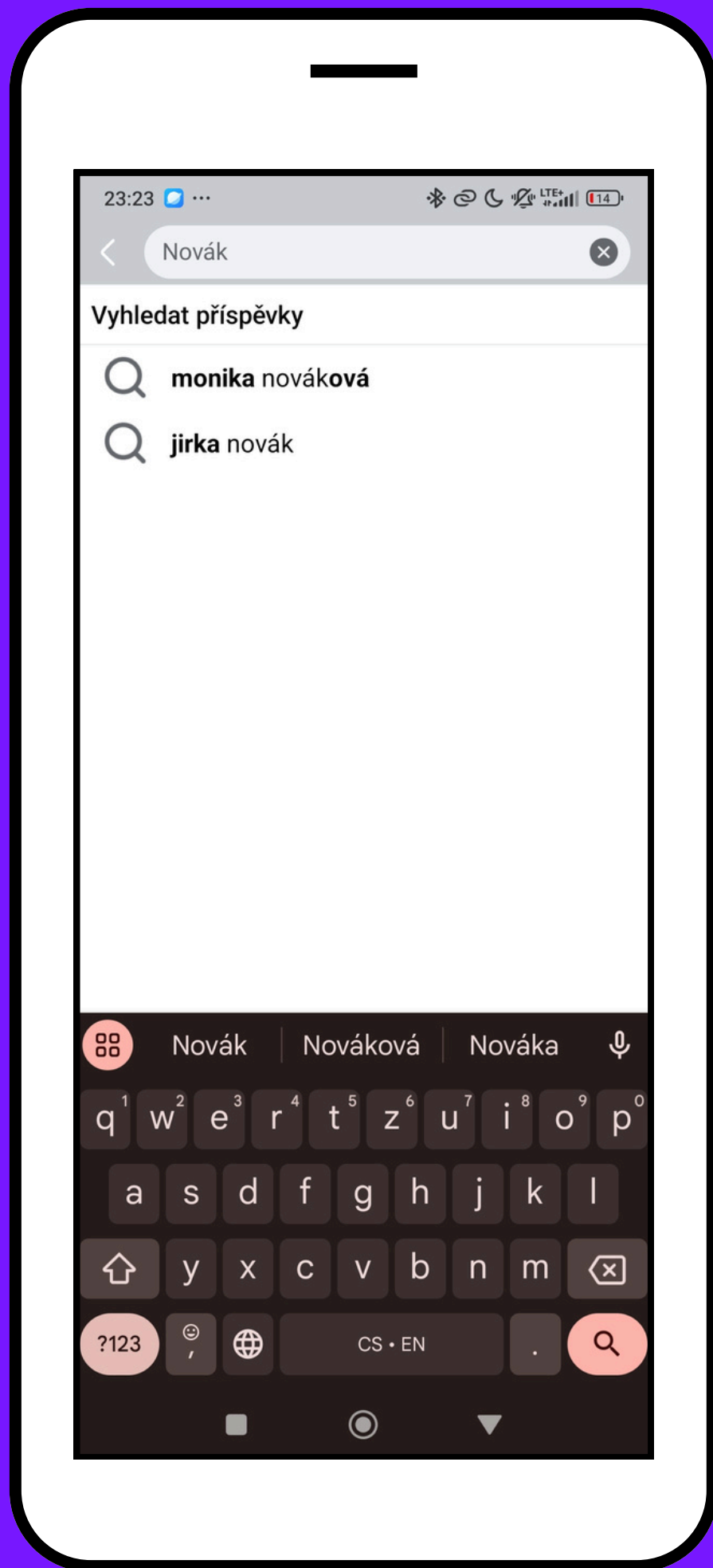

Onfine



Facebook

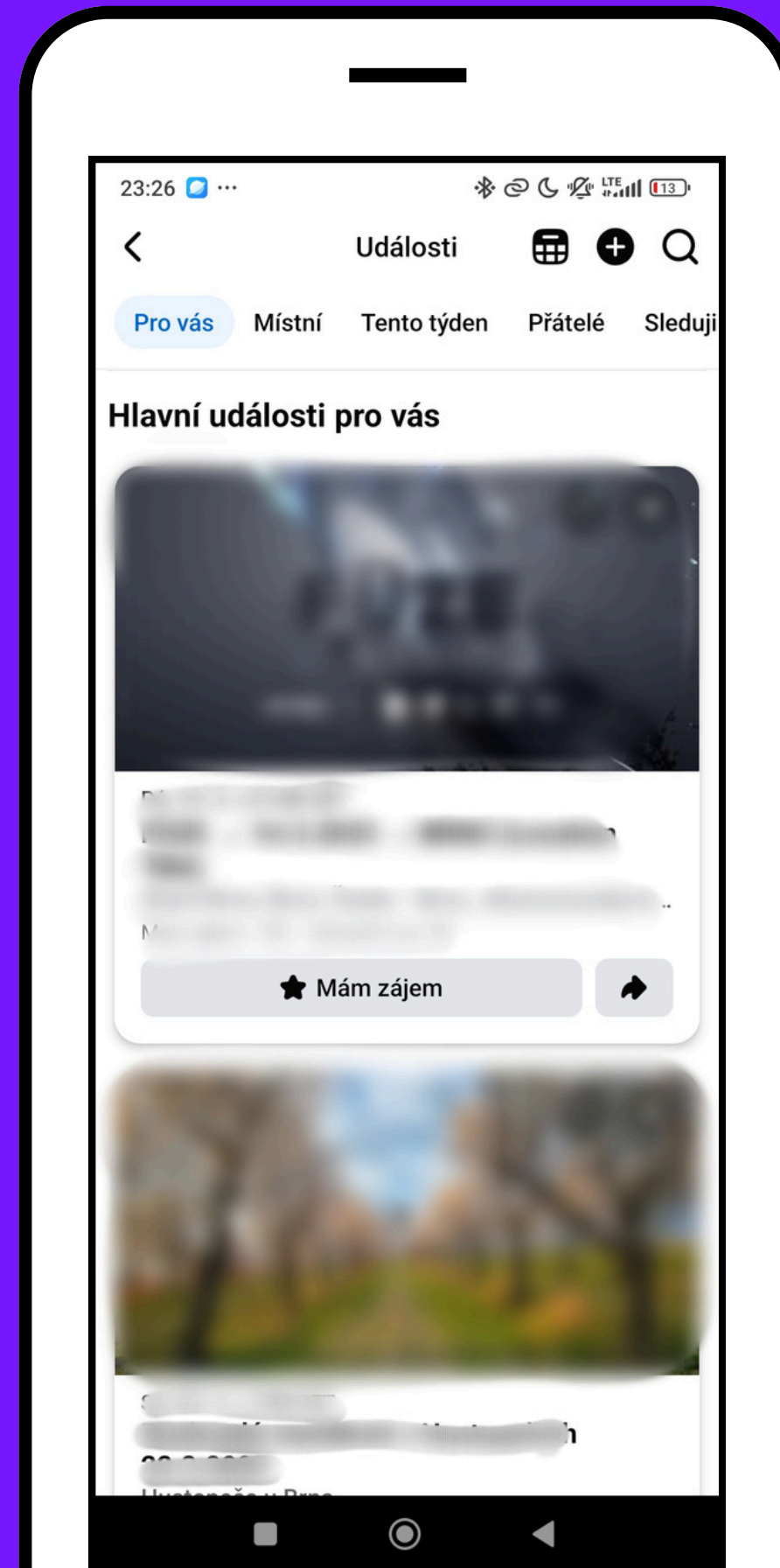
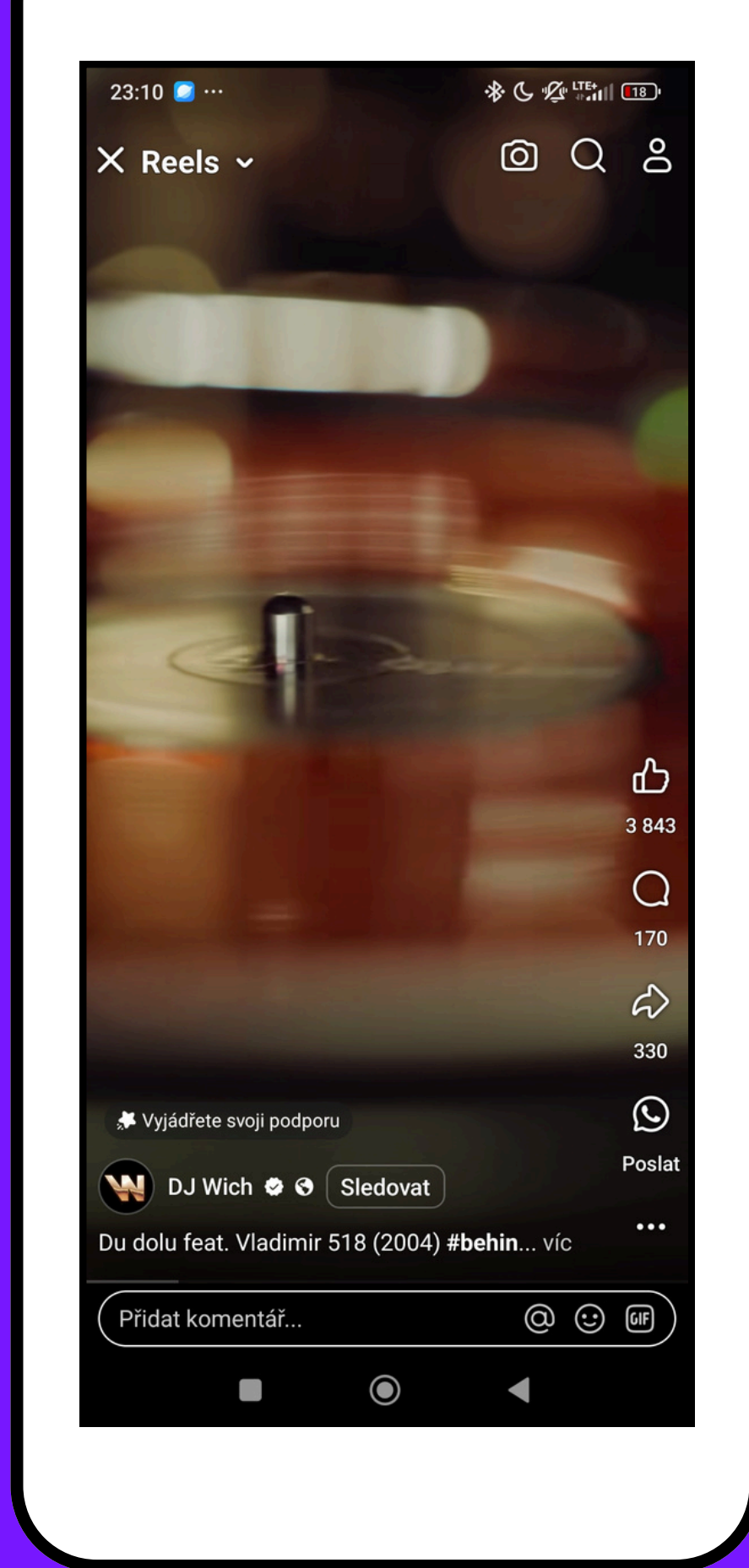

Online



Messenger

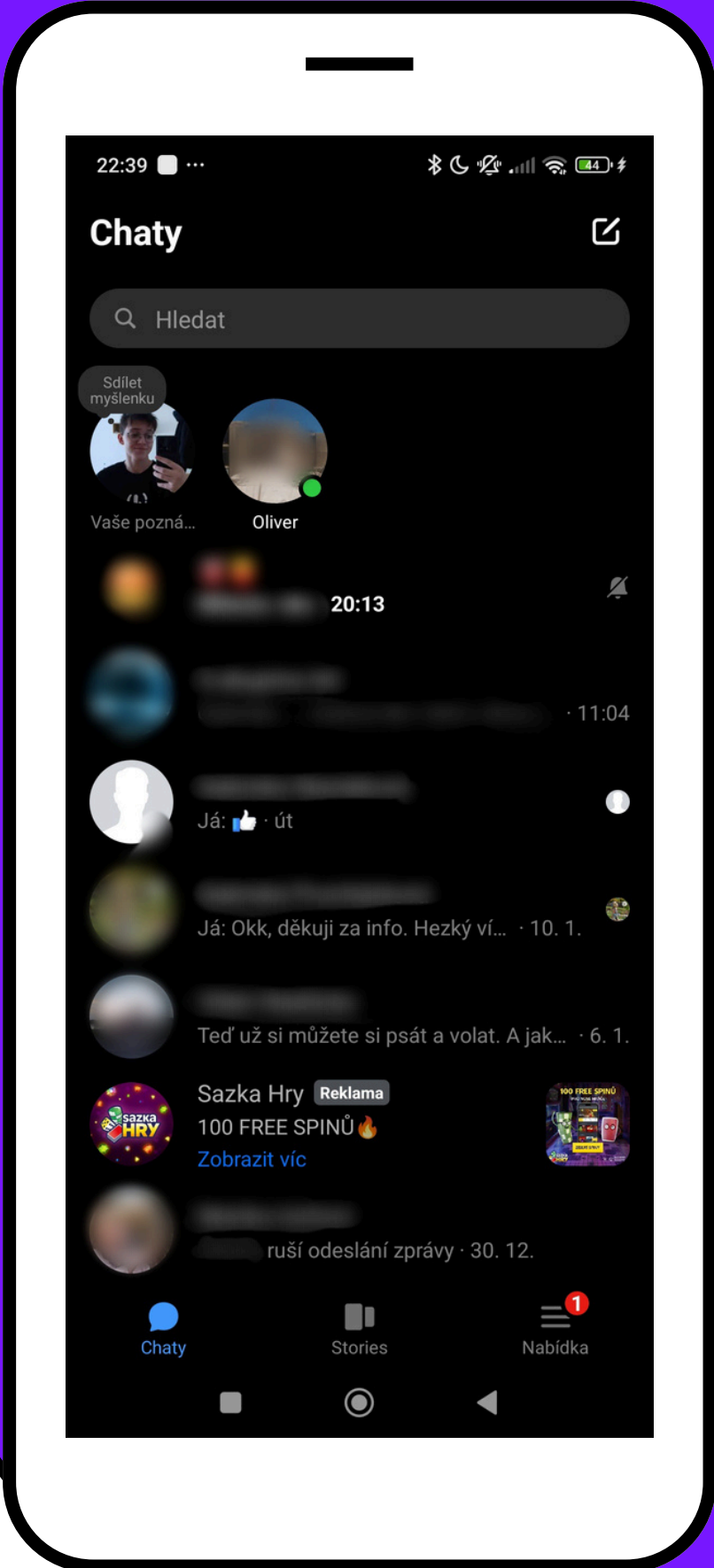
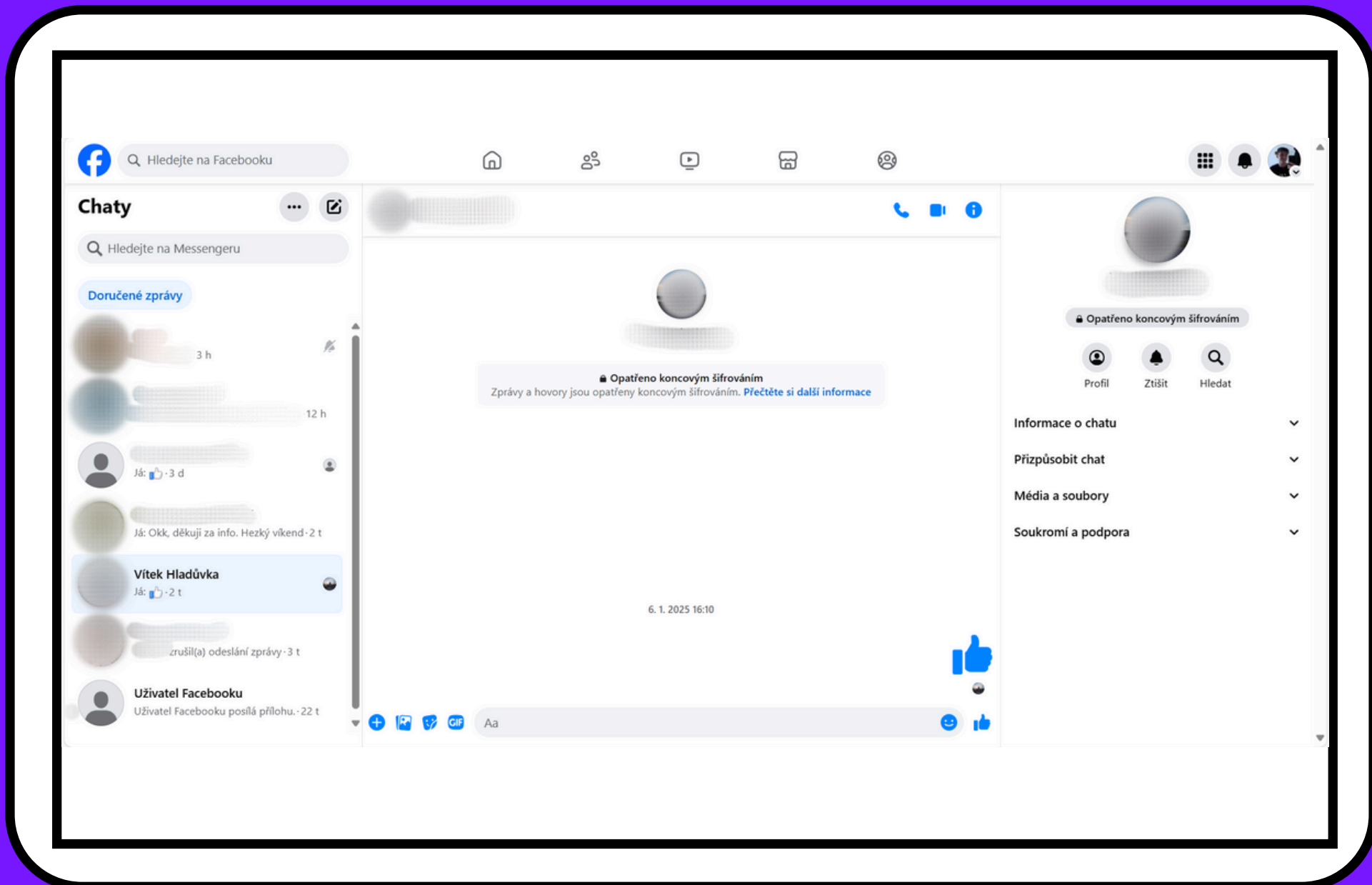

Online



Messenger

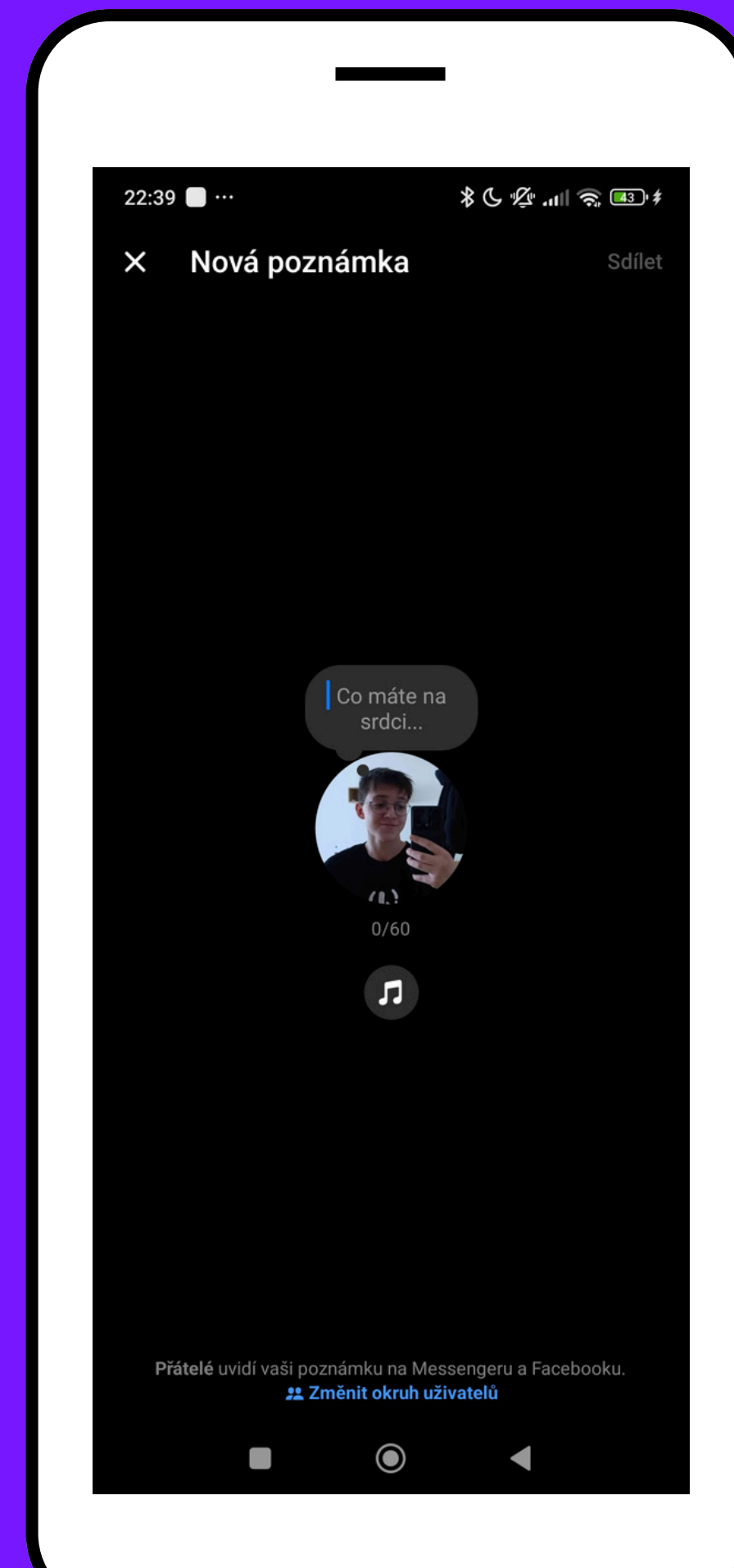
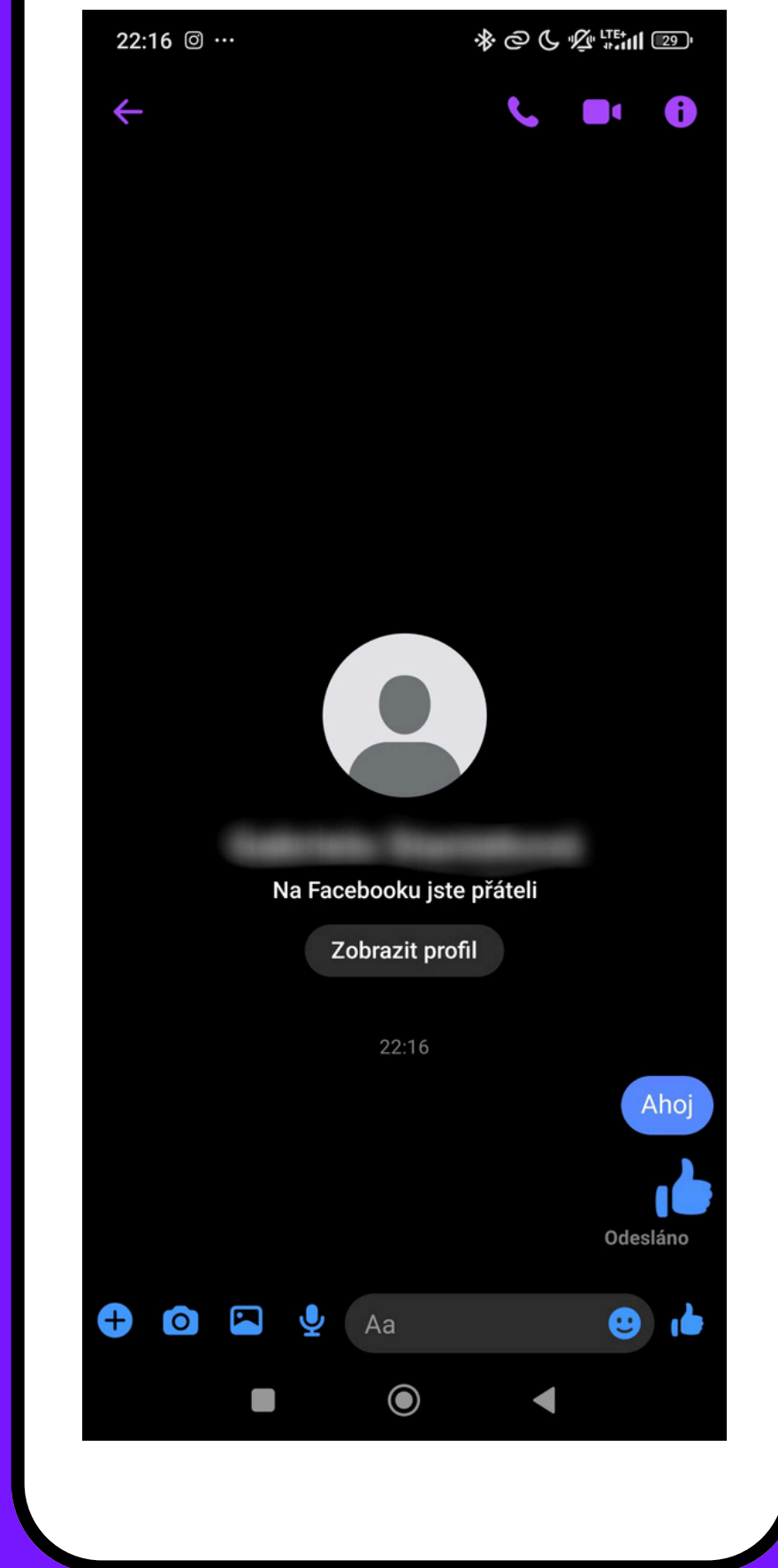
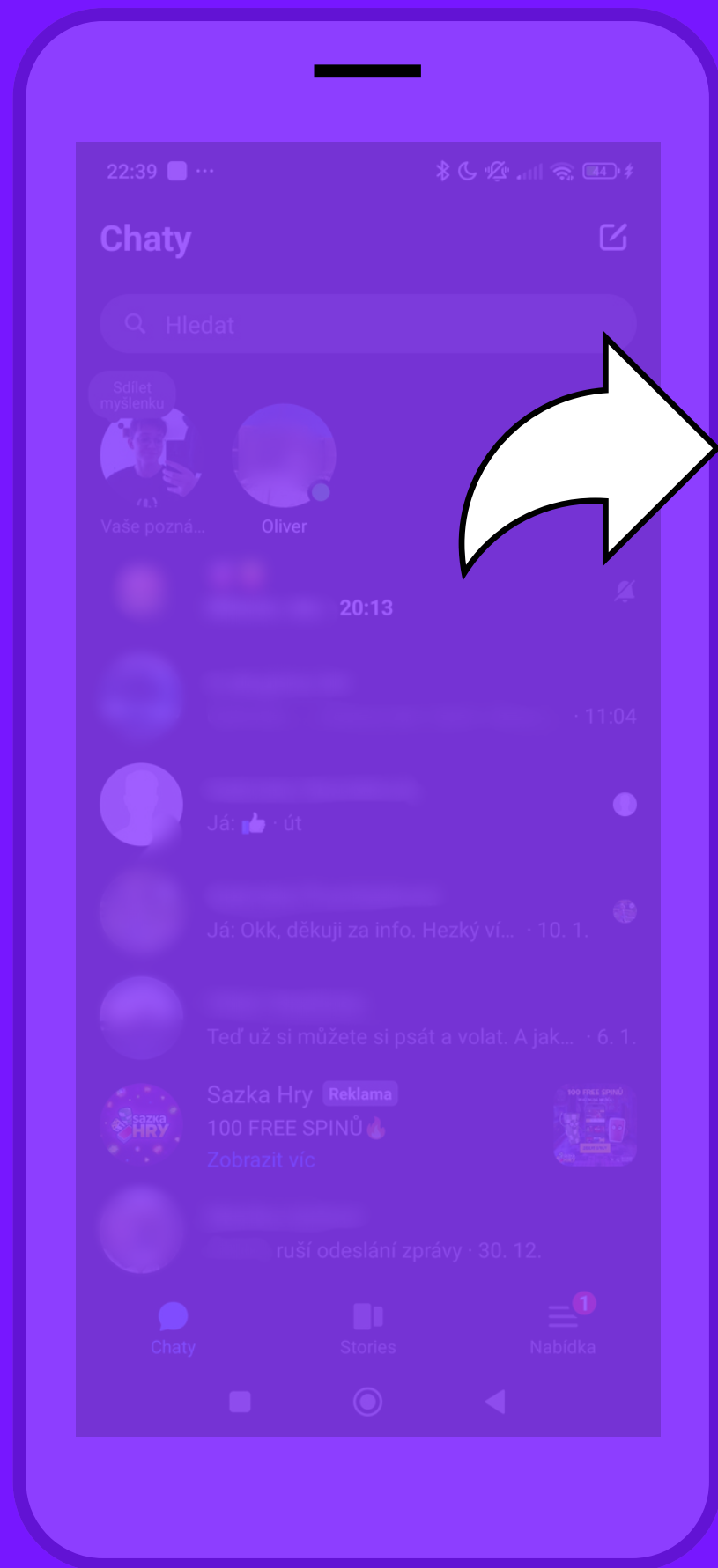

Online

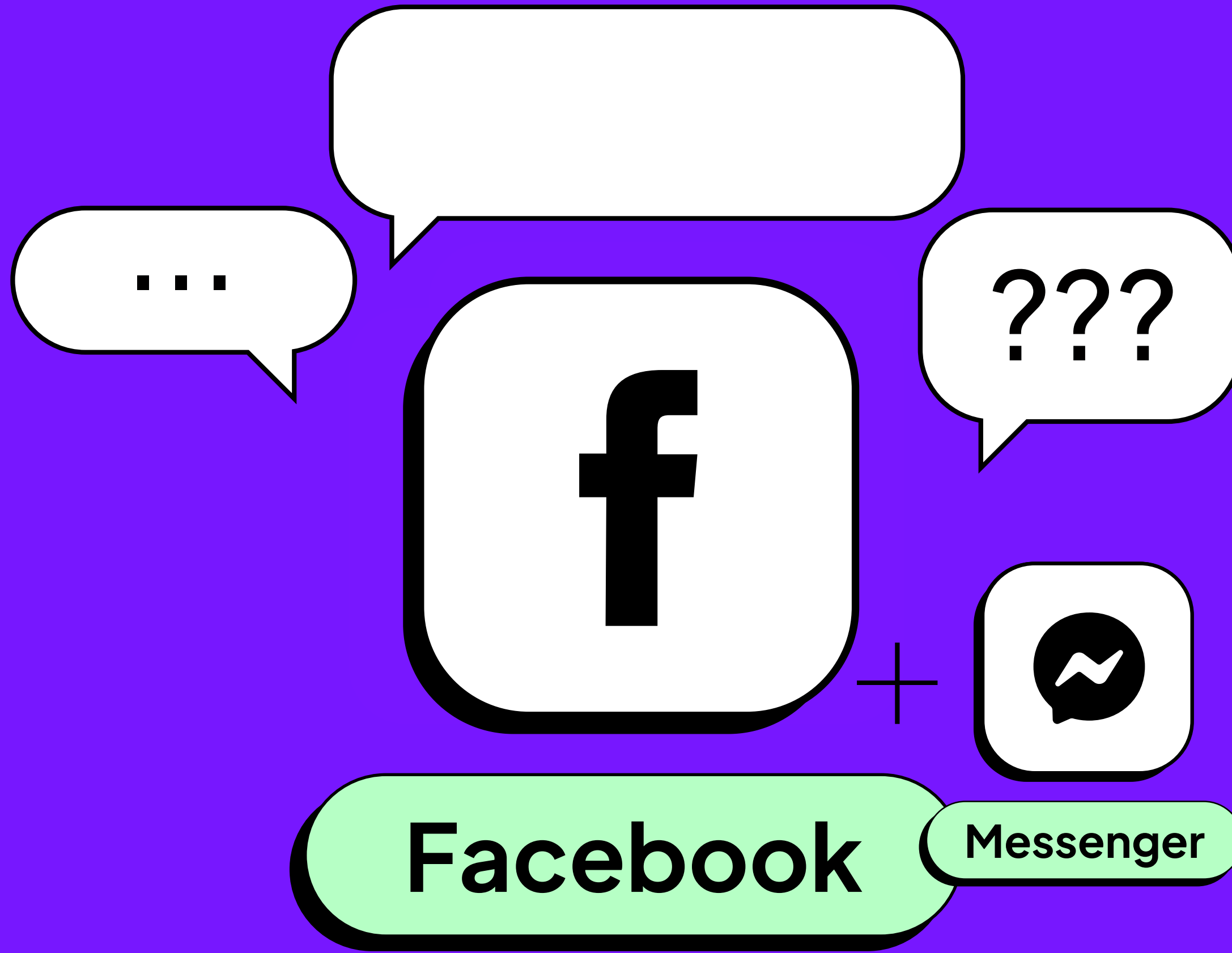

Online

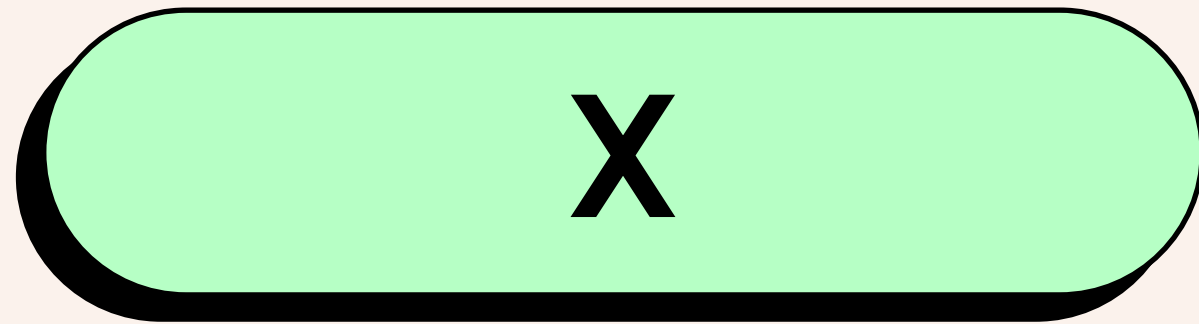
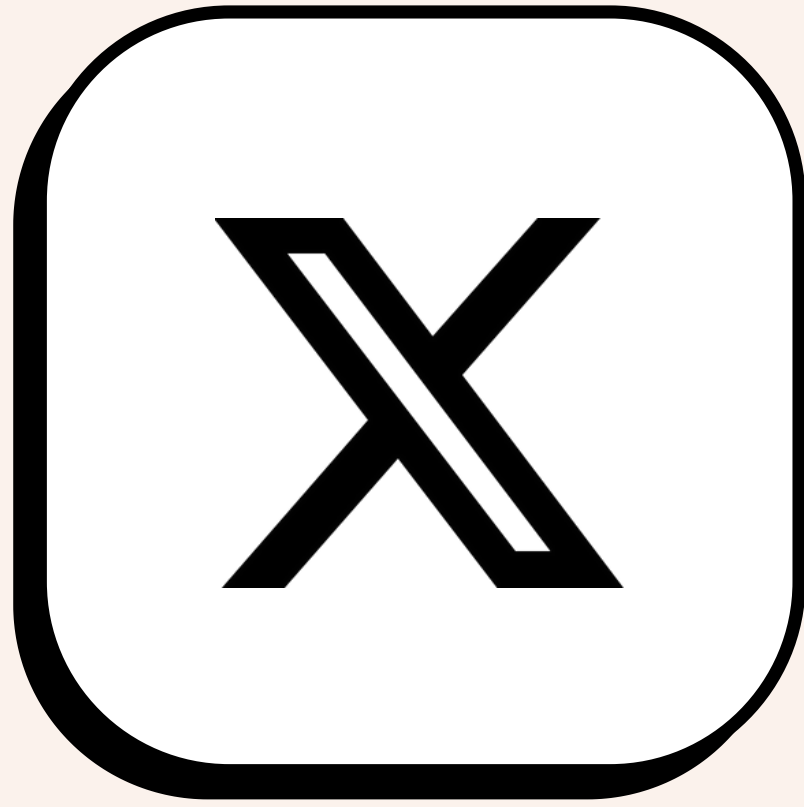

Online

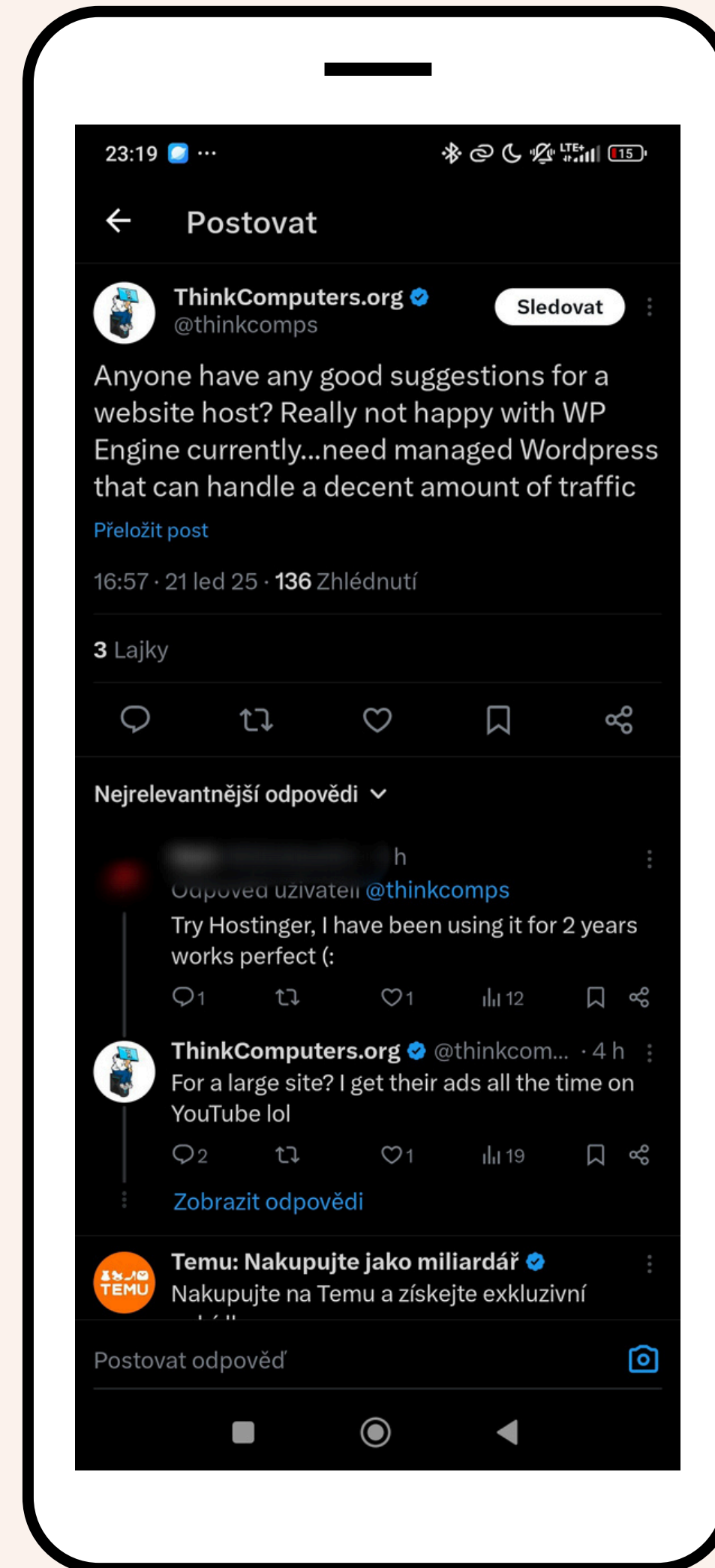
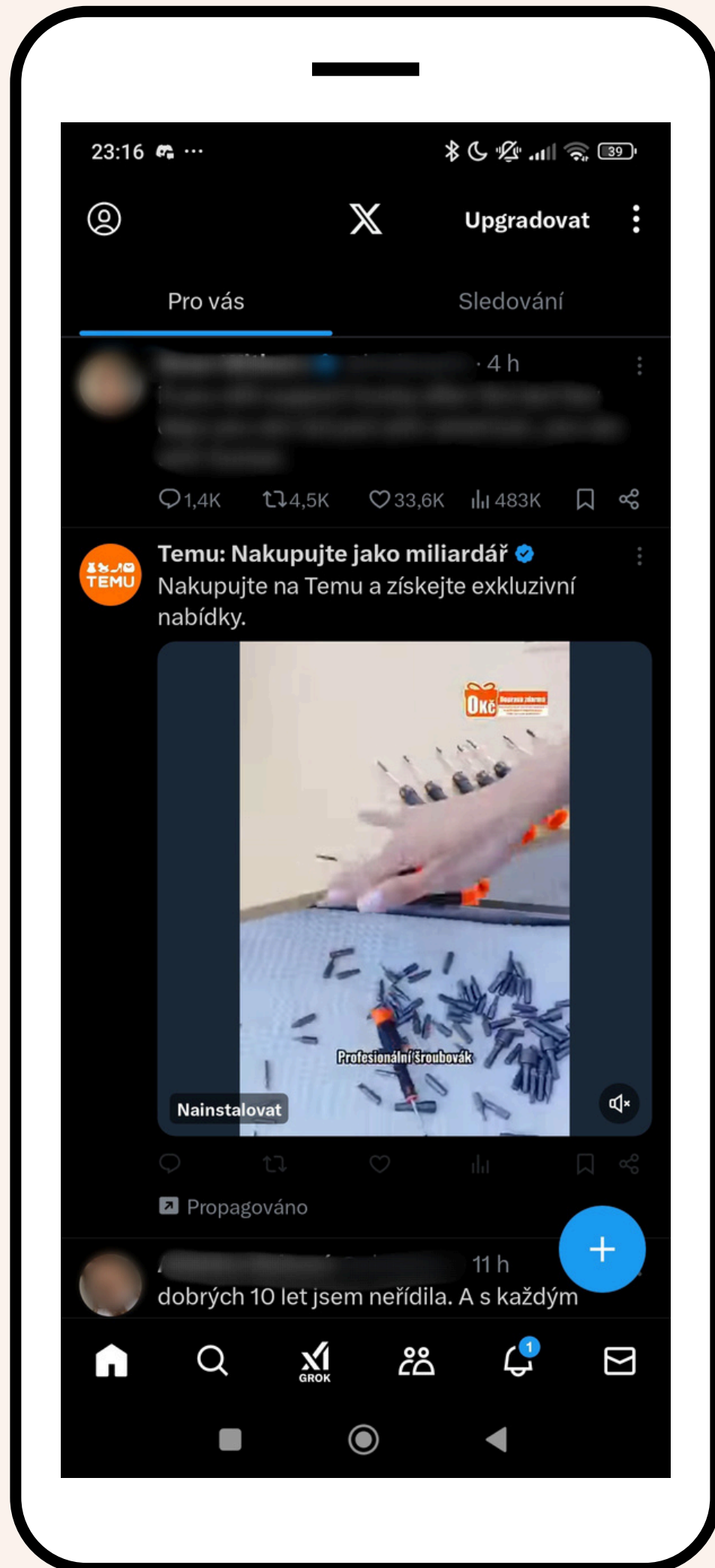
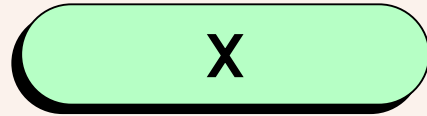
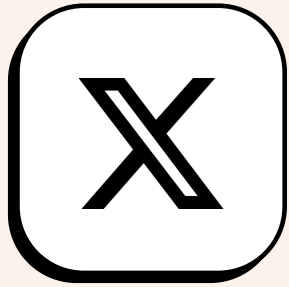

Online

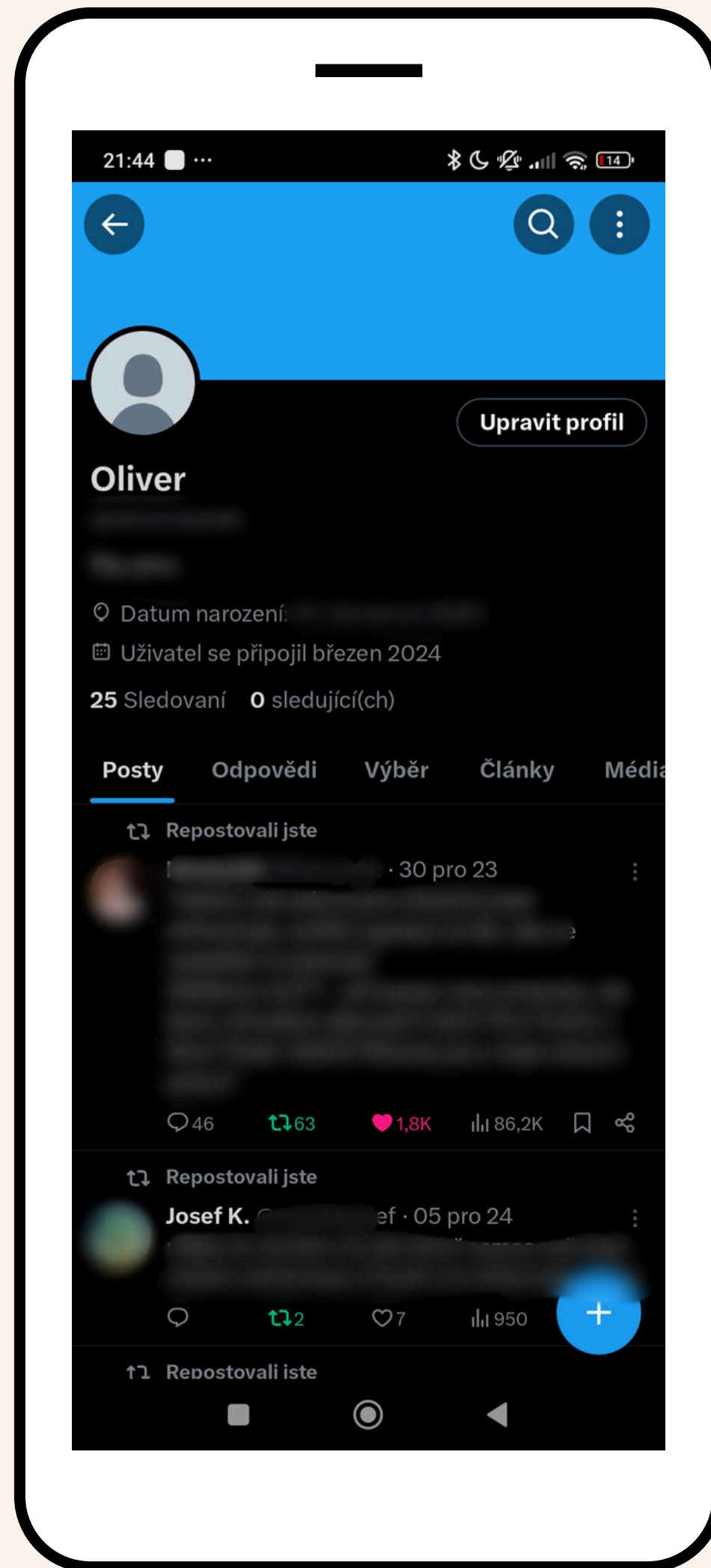
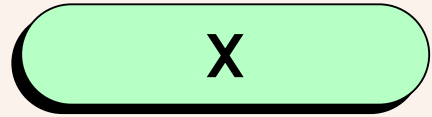
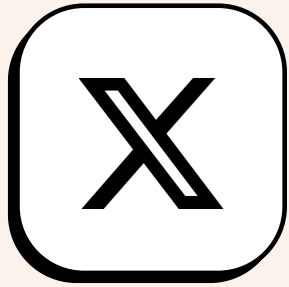

Onfine



X

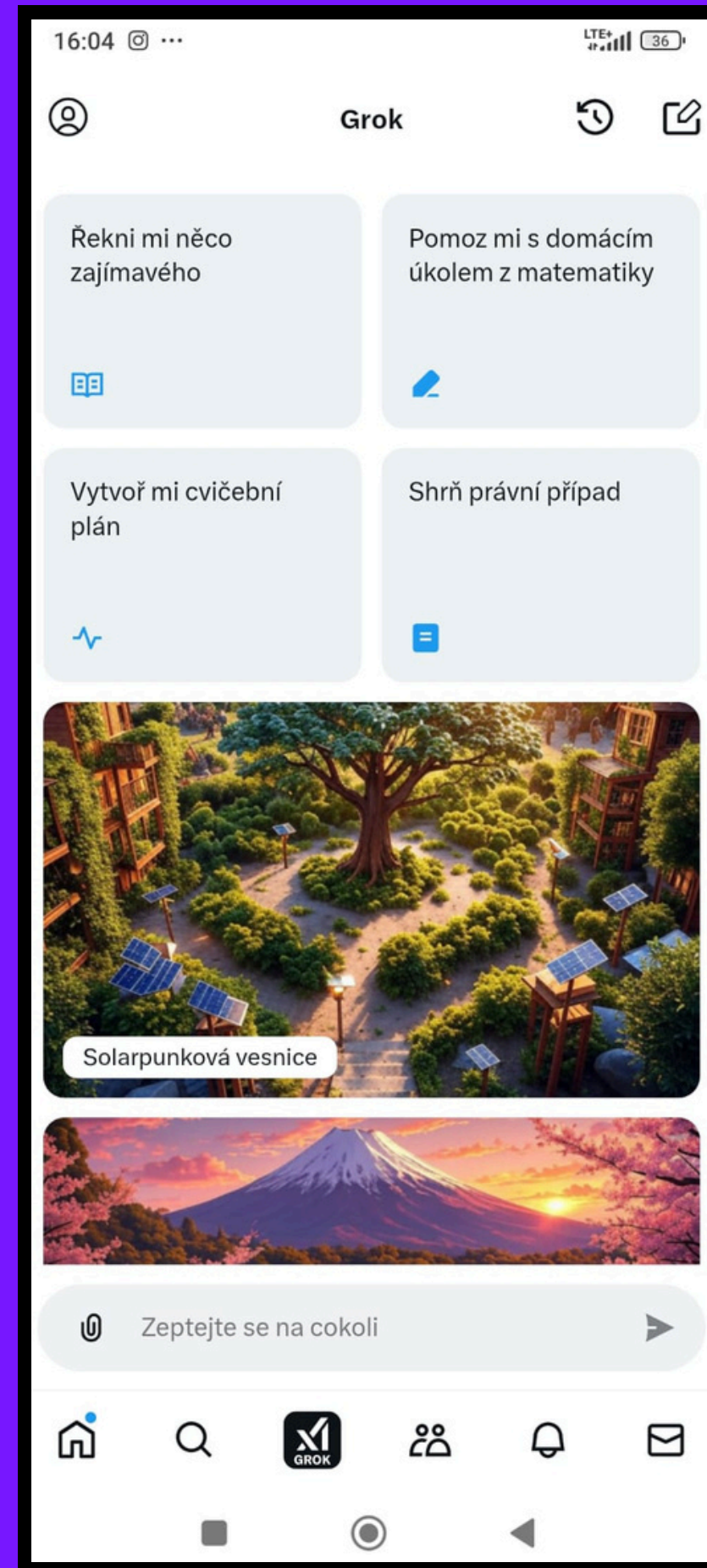
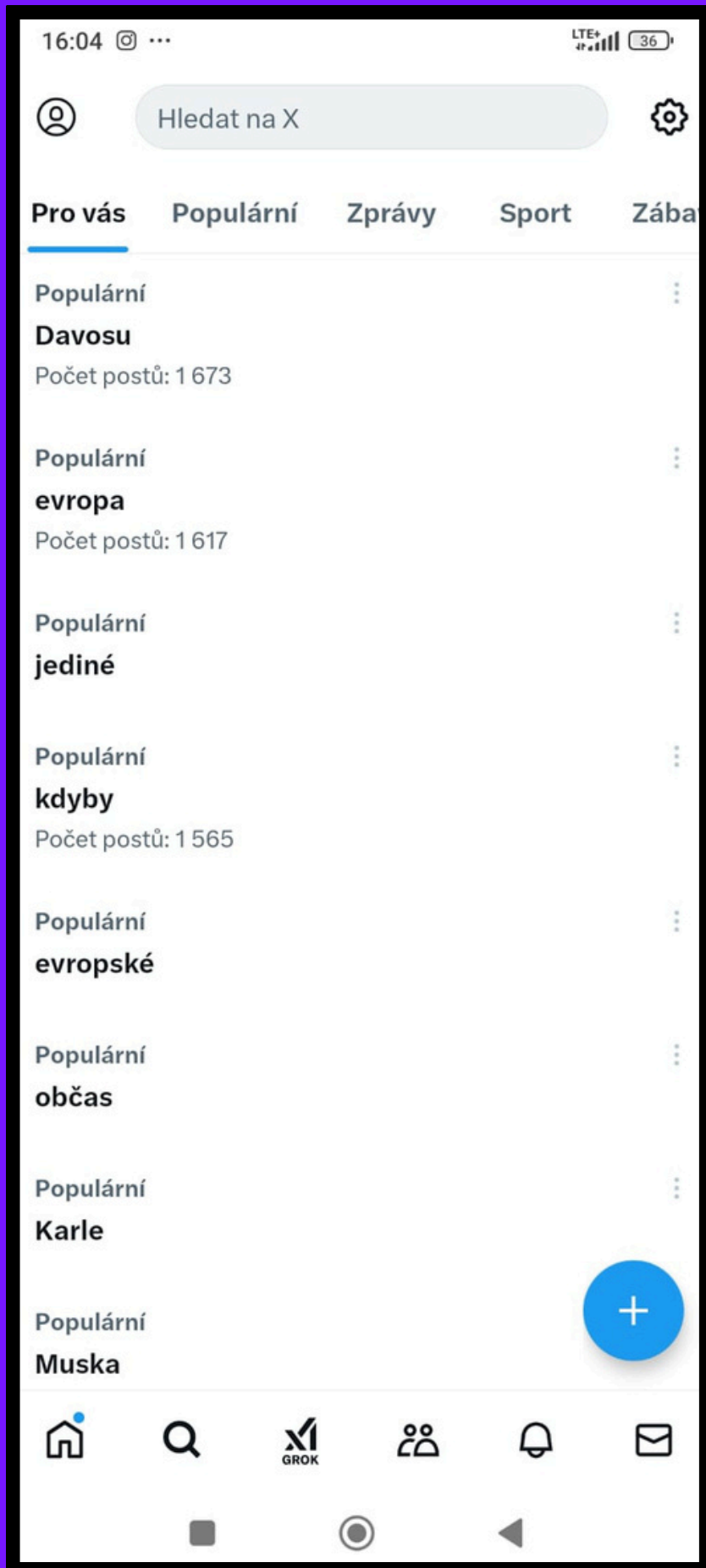

Online

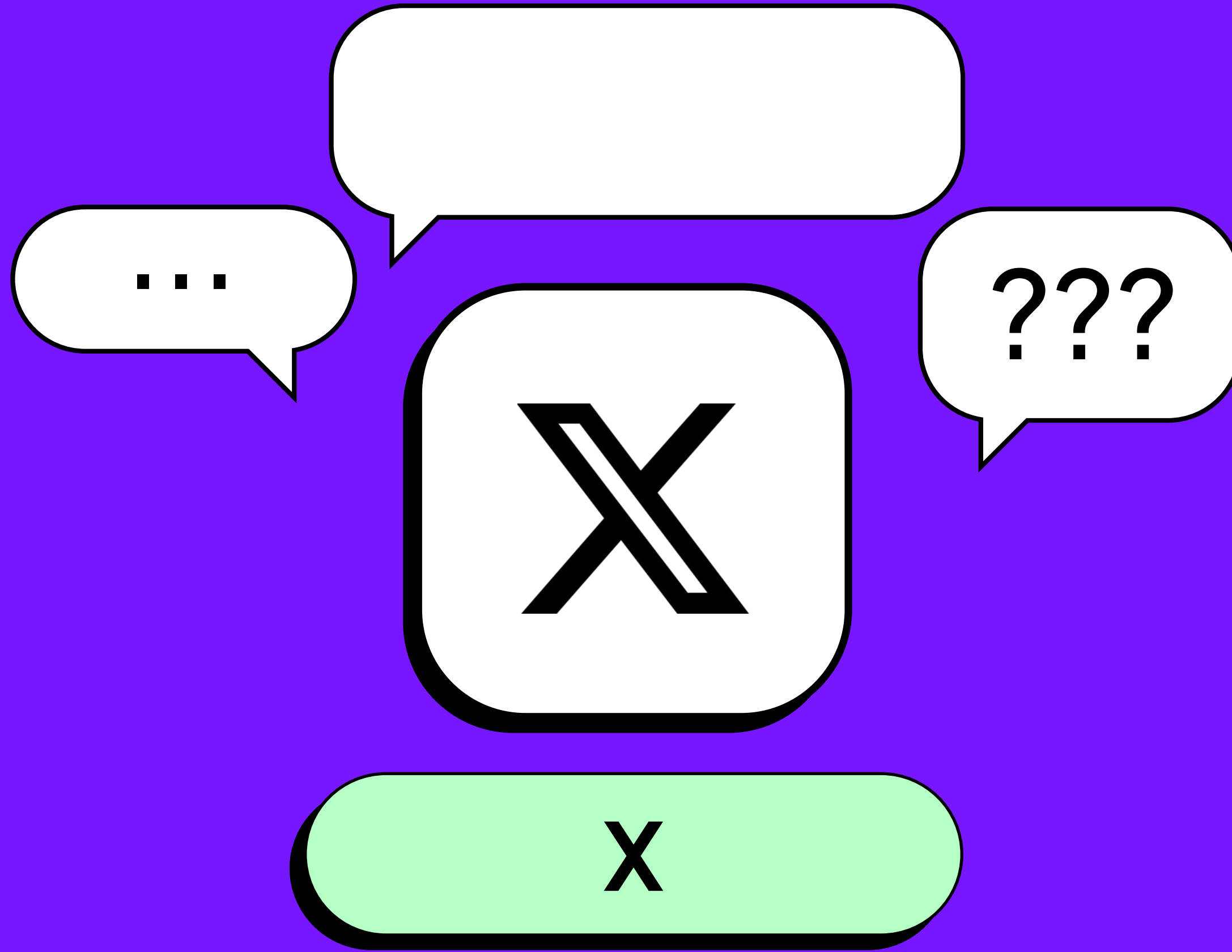

Online



YouTube

Online



YouTube

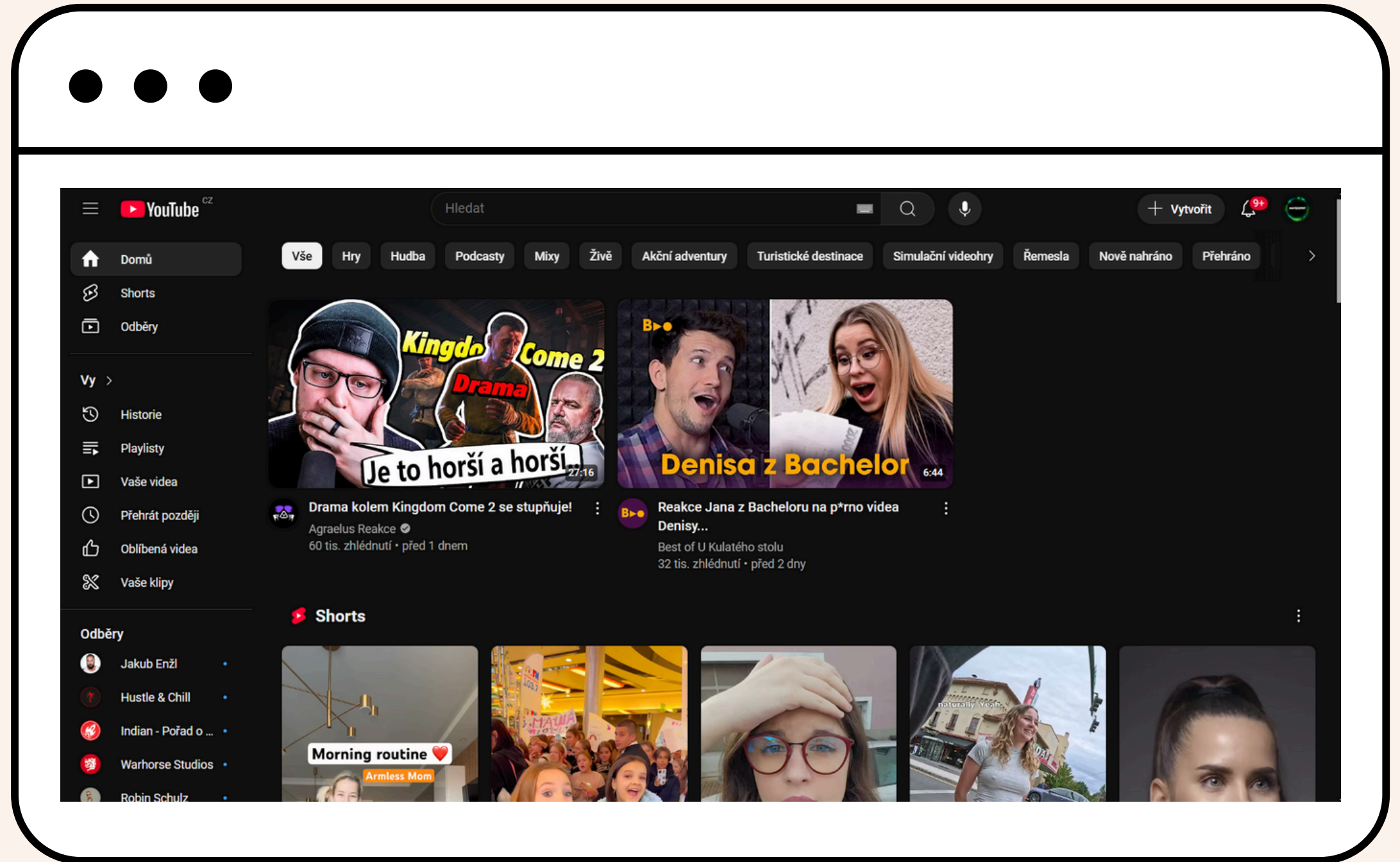
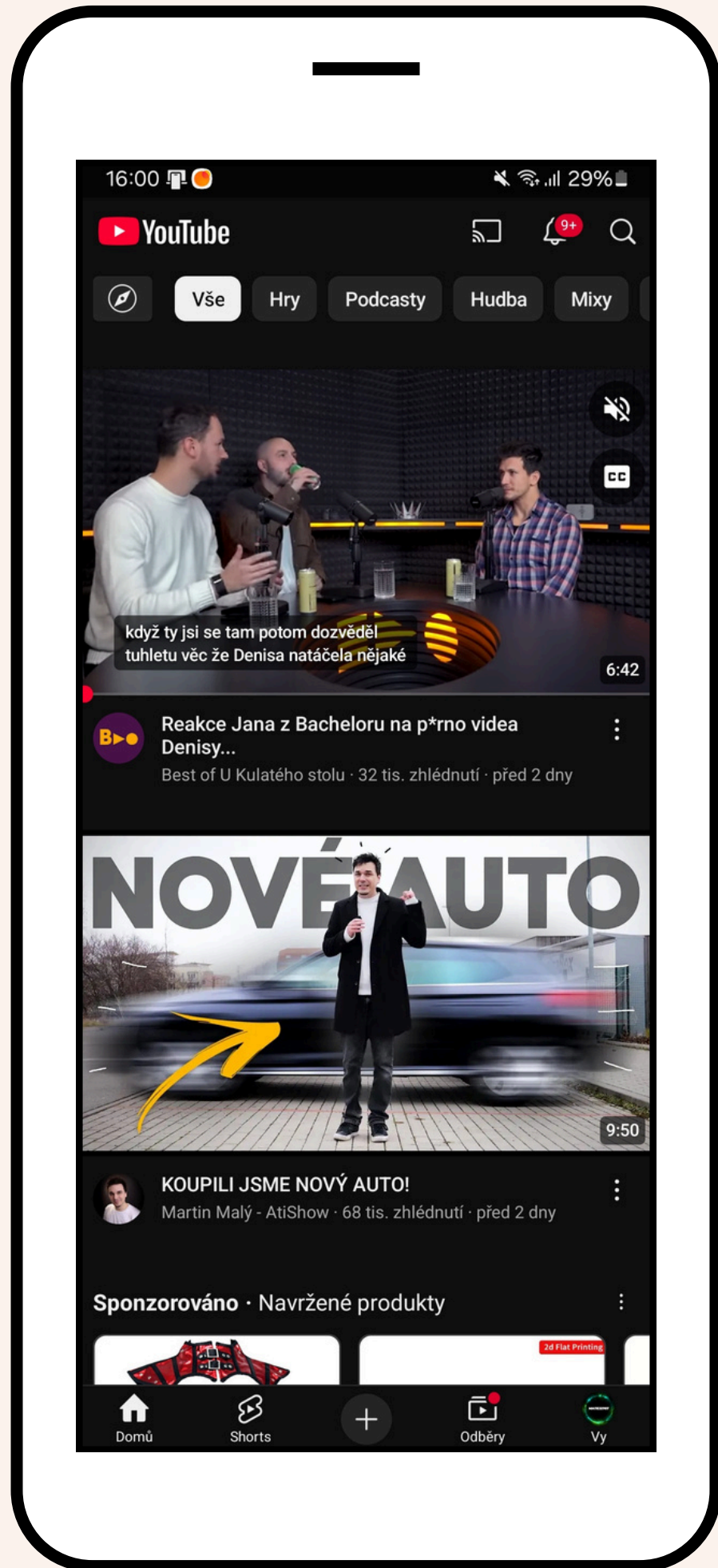

Onfine



YouTube

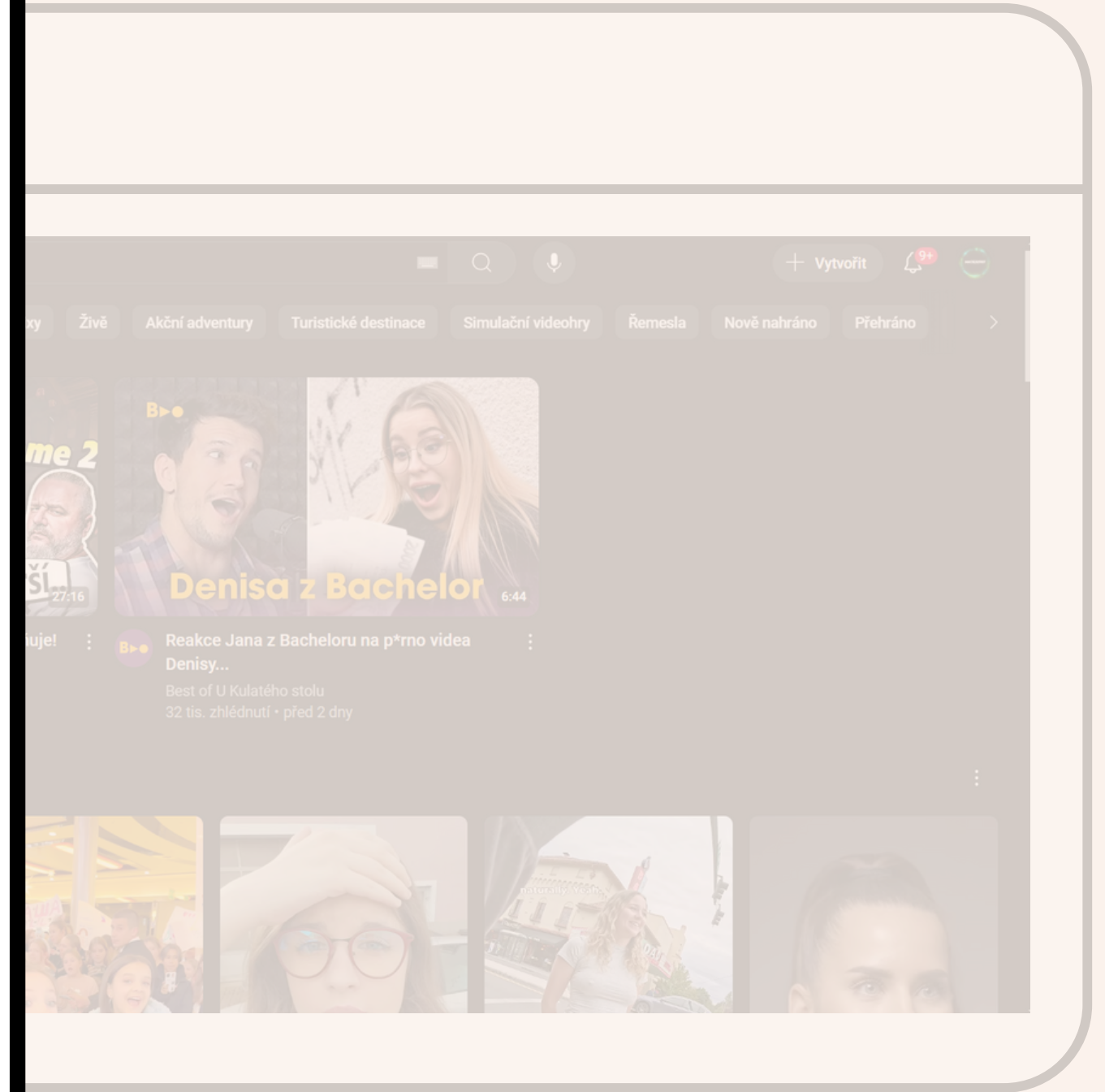
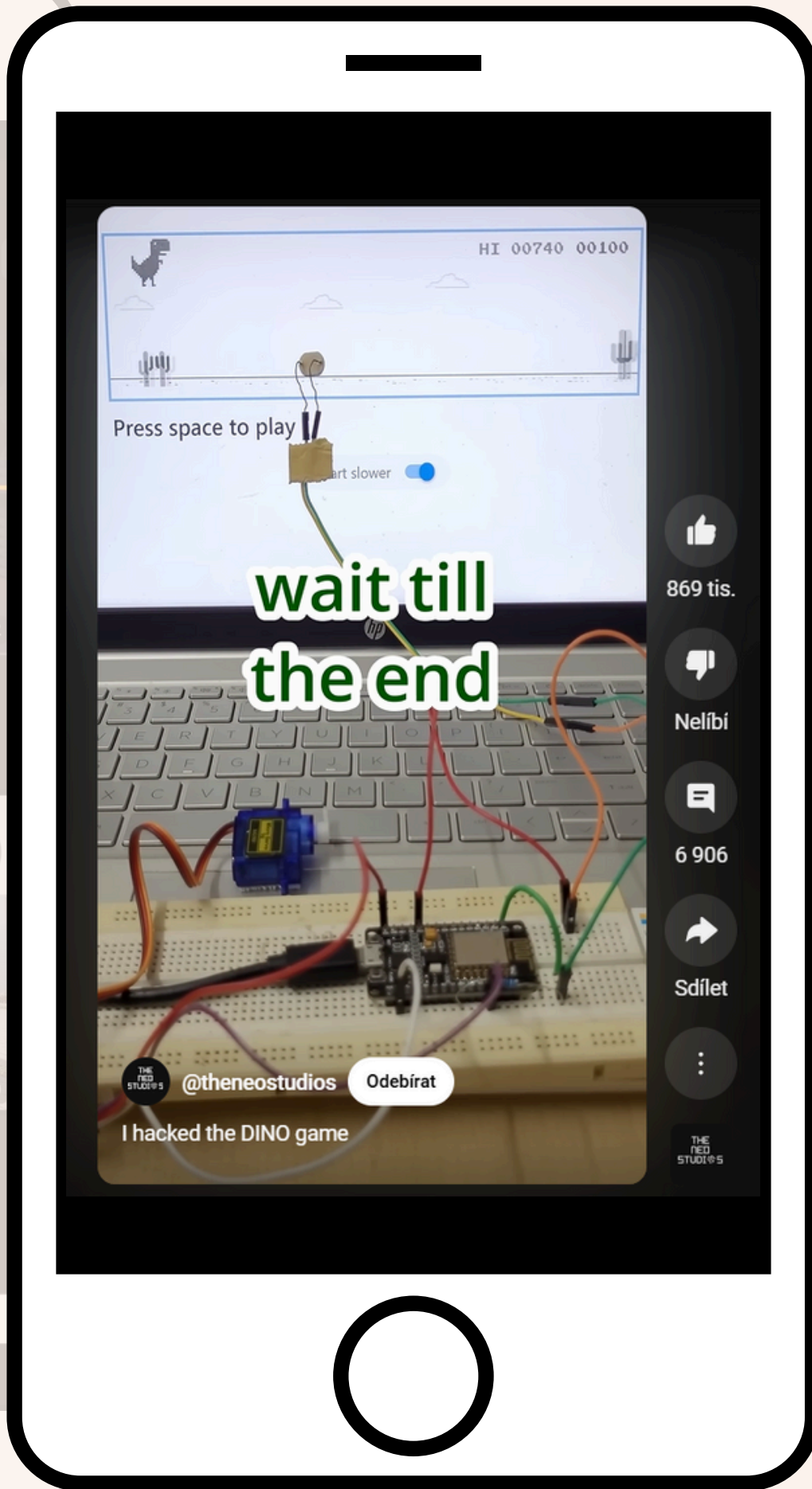
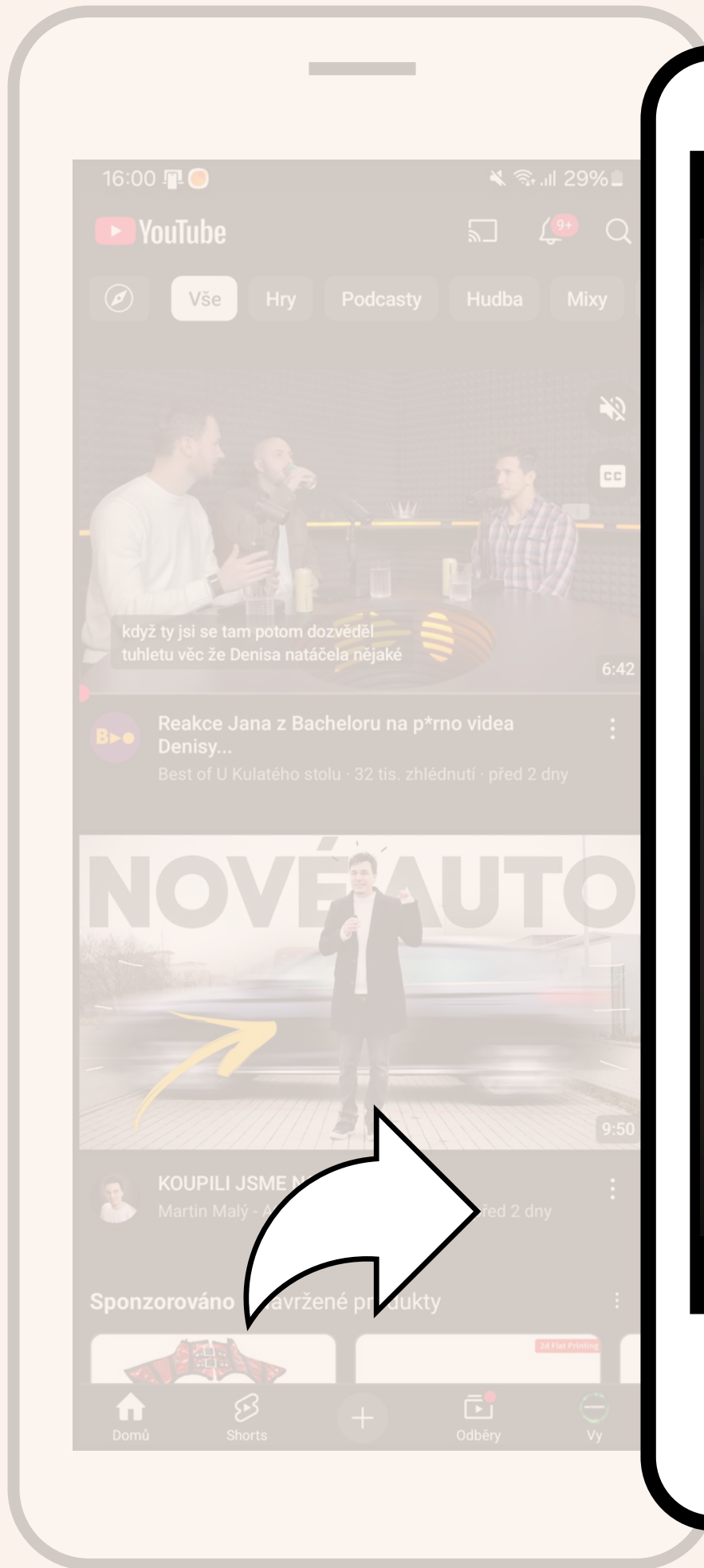

Online



YouTube

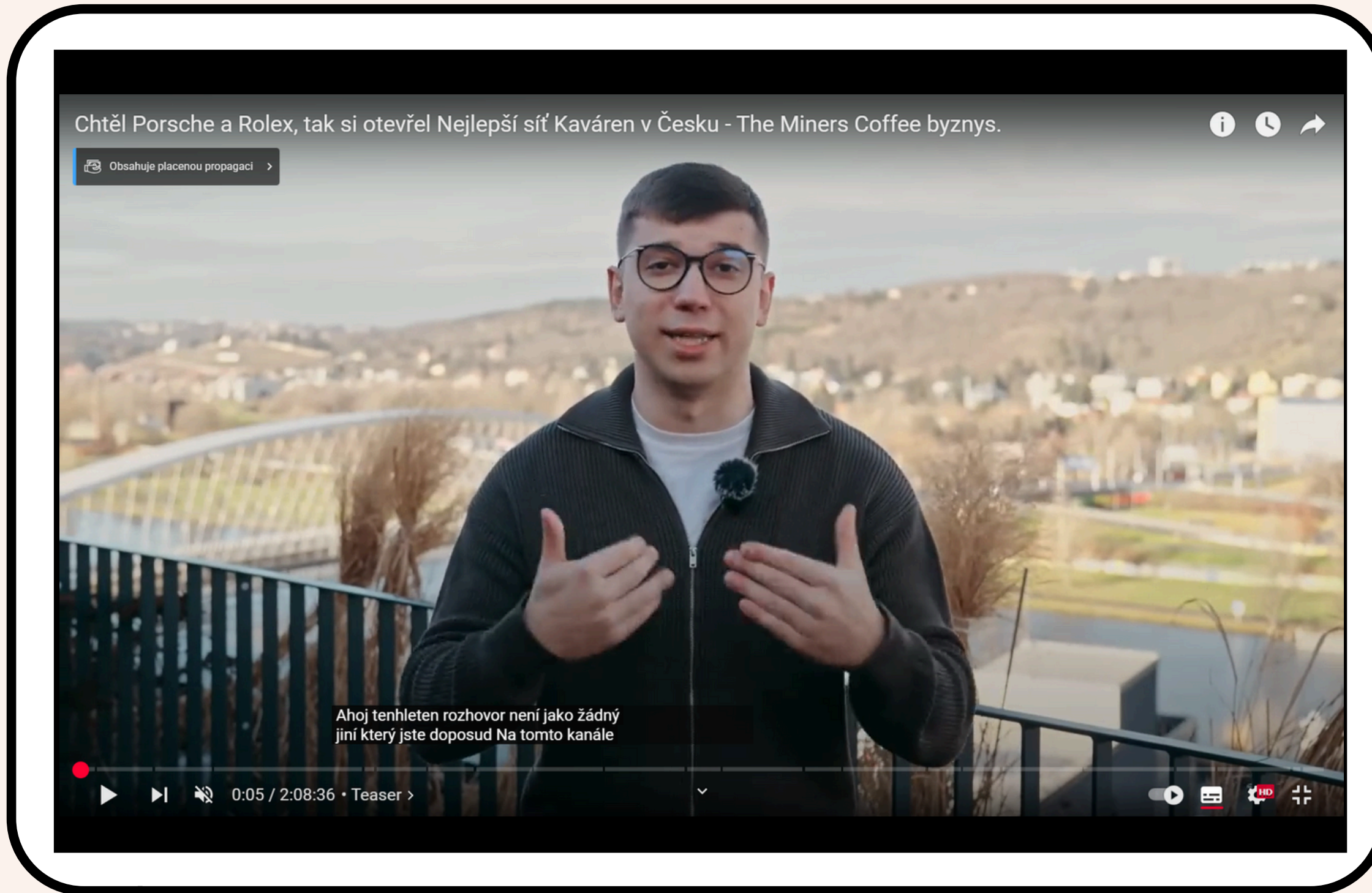

Online



YouTube

Jaké bude Kingdom Come 2? | Vávra, Čočík, Rybka, Tuček, TartarusCast | Nejlepší Podcast SPECIÁL



V.O.X. NEWS

72 tis. odběratelů

Připojit se

Odebírat

5 tis.

Sdílet

Stáhnout

150 tis. zhlédnutí před 12 dny Nejlepší Podcast

🎁 Novoroční dáreček od V.O.X. TV! Užijte si celý rozhovor v nezkrácené verzi zdarma! Daniel Vávra, Tomáš Petráček z TartarusCast, Michal Rybka, Mikoláš Tuček a Lukáš Codr alias Čočík! Videoherní legendy o současném průmyslu, nových i starých hrách. Jaké je nejlepší RPG všech dob? Proč stojí nové hry stovky milionů dolarů? A proč AAA hry zažívají úpadek? Dostane se i na Kingdom Come: Deliverance 2! Vítejte u Nejlepšího Po ...více

782 komentářů

Řadit podle



Okomentovat...



📌 Připnuto autorem V.O.X. NEWS

@vox-news před 12 dny

🎁 Novoroční dáreček od V.O.X. TV! Užijte si celý rozhovor v nezkrácené verzi zdarma! Podpořit nás můžete na našem webu, kde najdete již nyní další díl s Tarrou White a Paulou Wild 😊 18+!

<https://www.voxtv.cz/show/nejlepsi-podcast/zakulisi-pornoprumsly-kolik-si-vydelala-tarra-white-v-dobe-nejvetsi-slavy>

101



Odpovědět

Online



YouTube

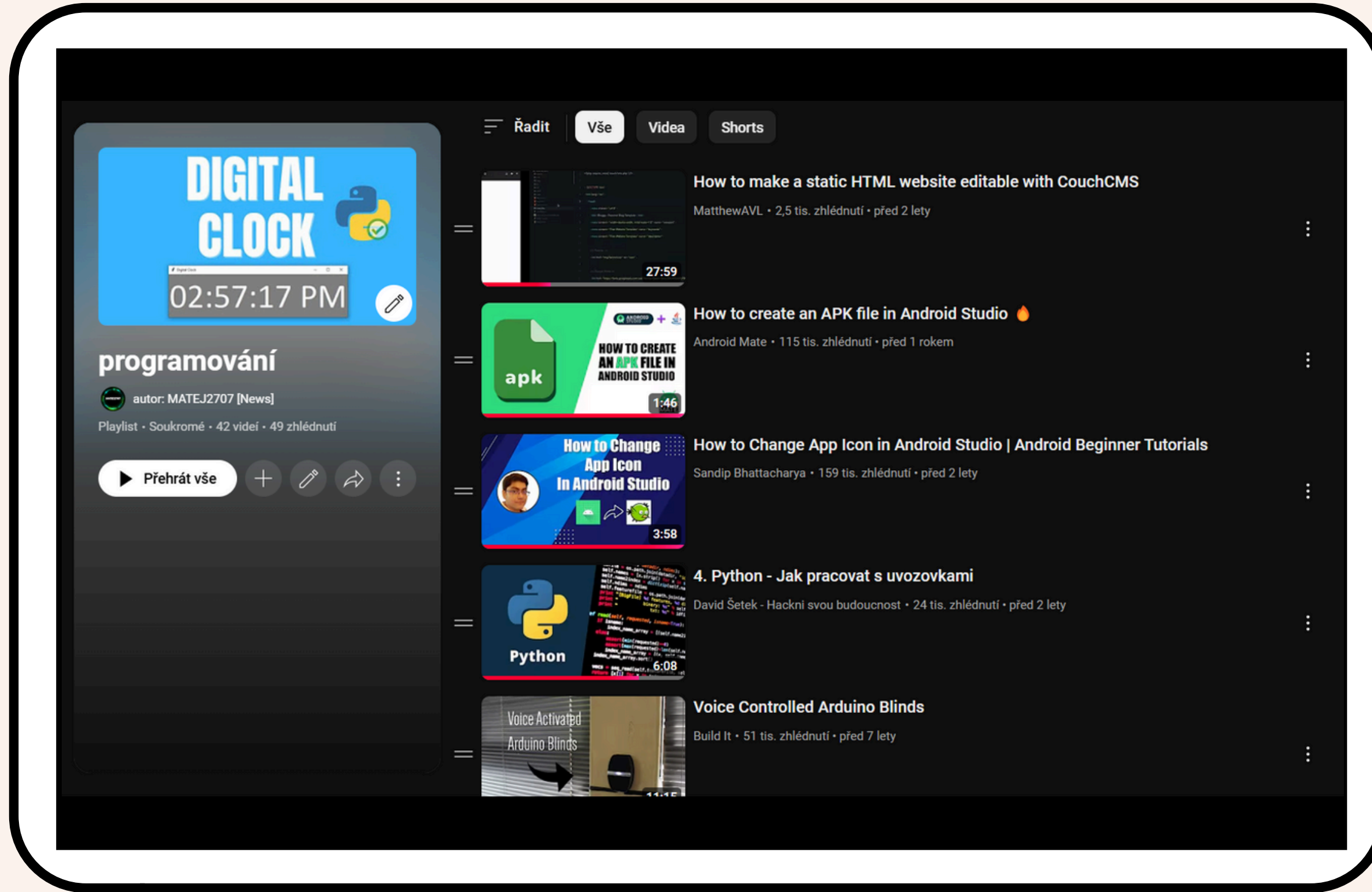

Online



YouTube

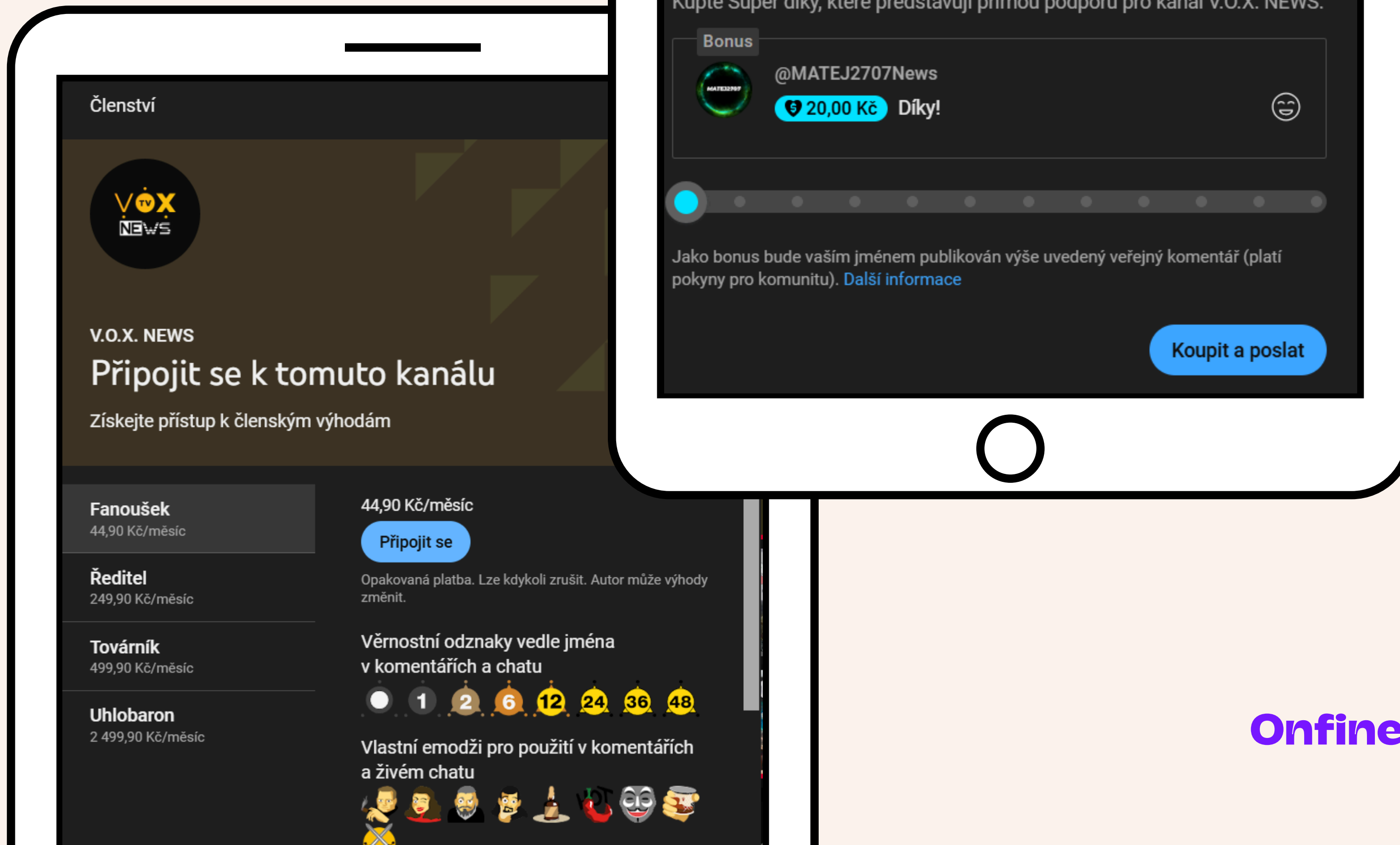

Onfine

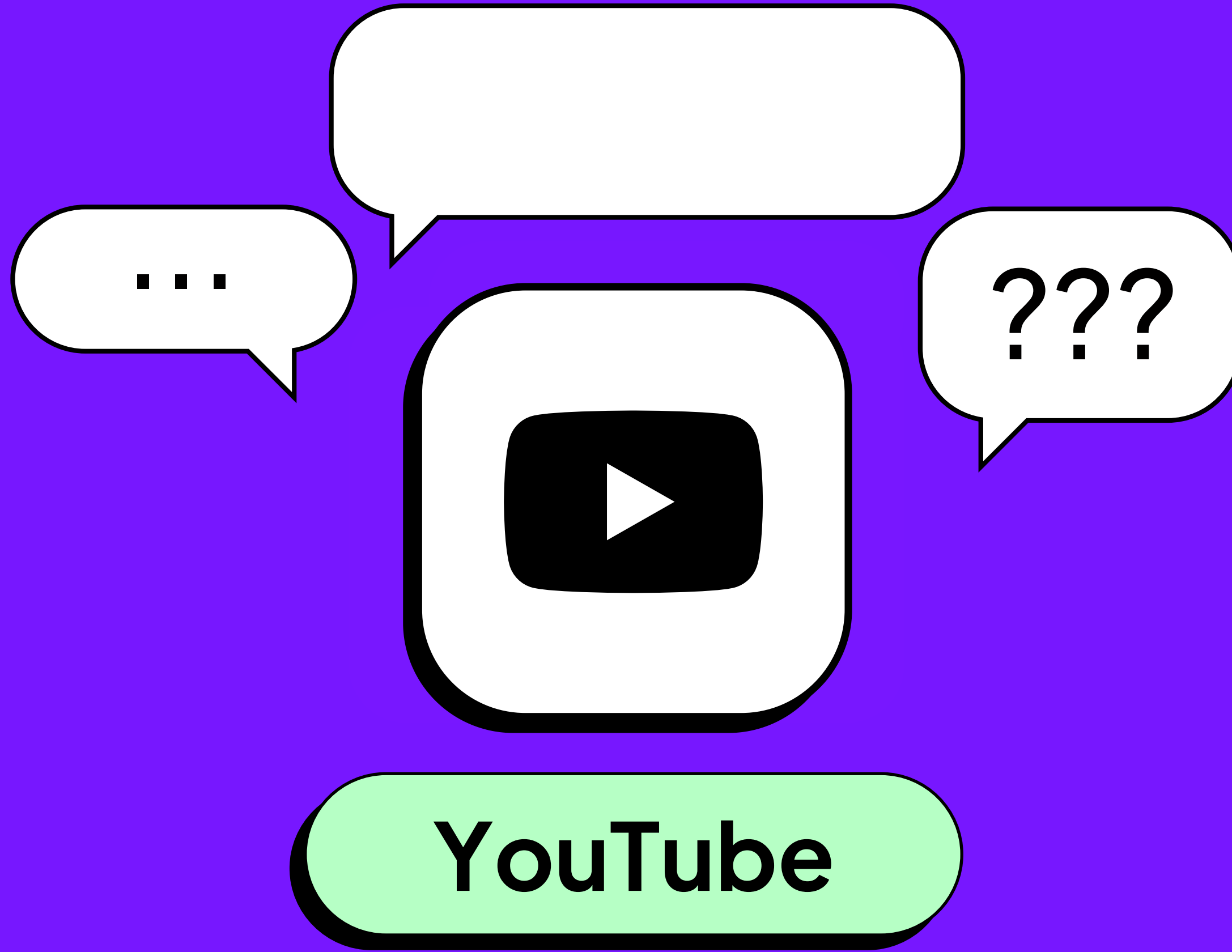

Online



WhatsApp

Online



WhatsApp

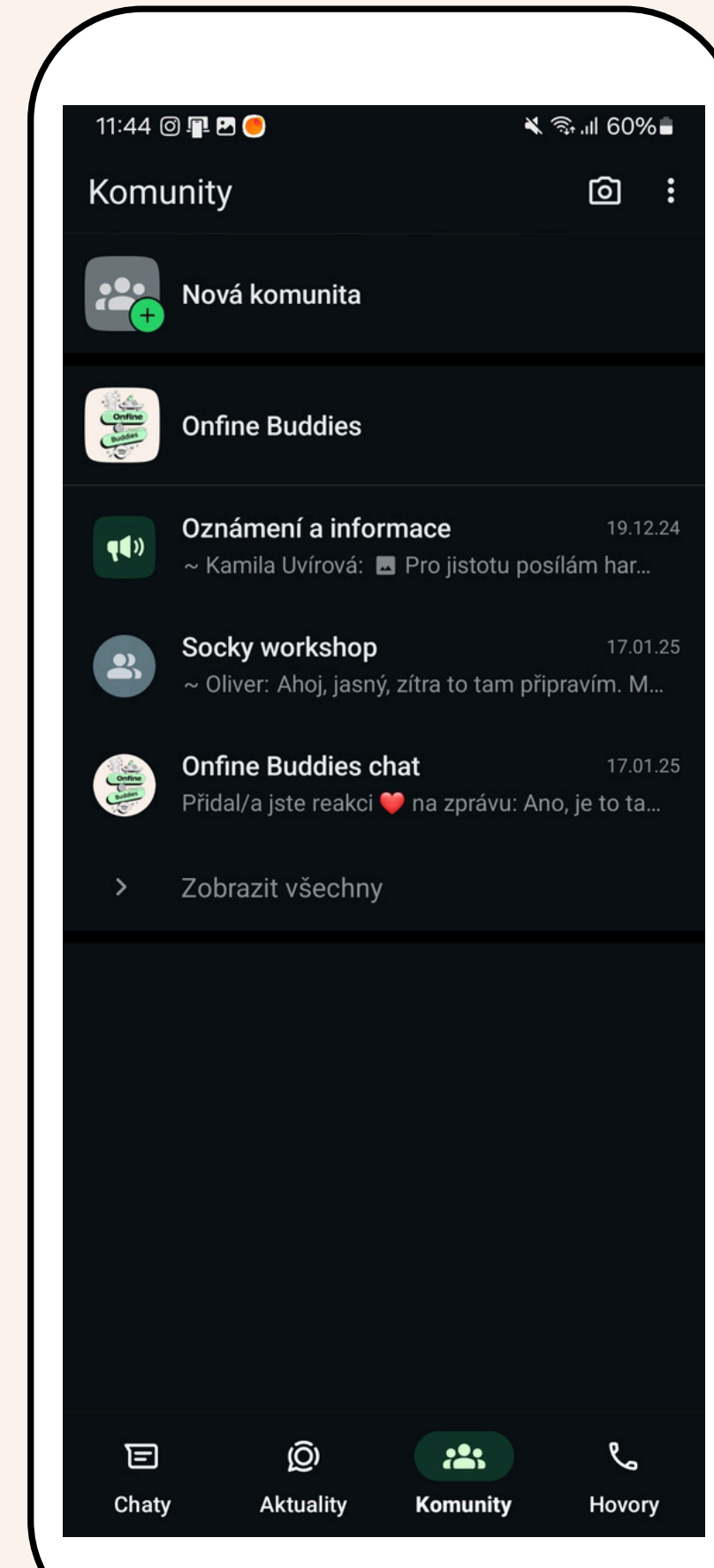
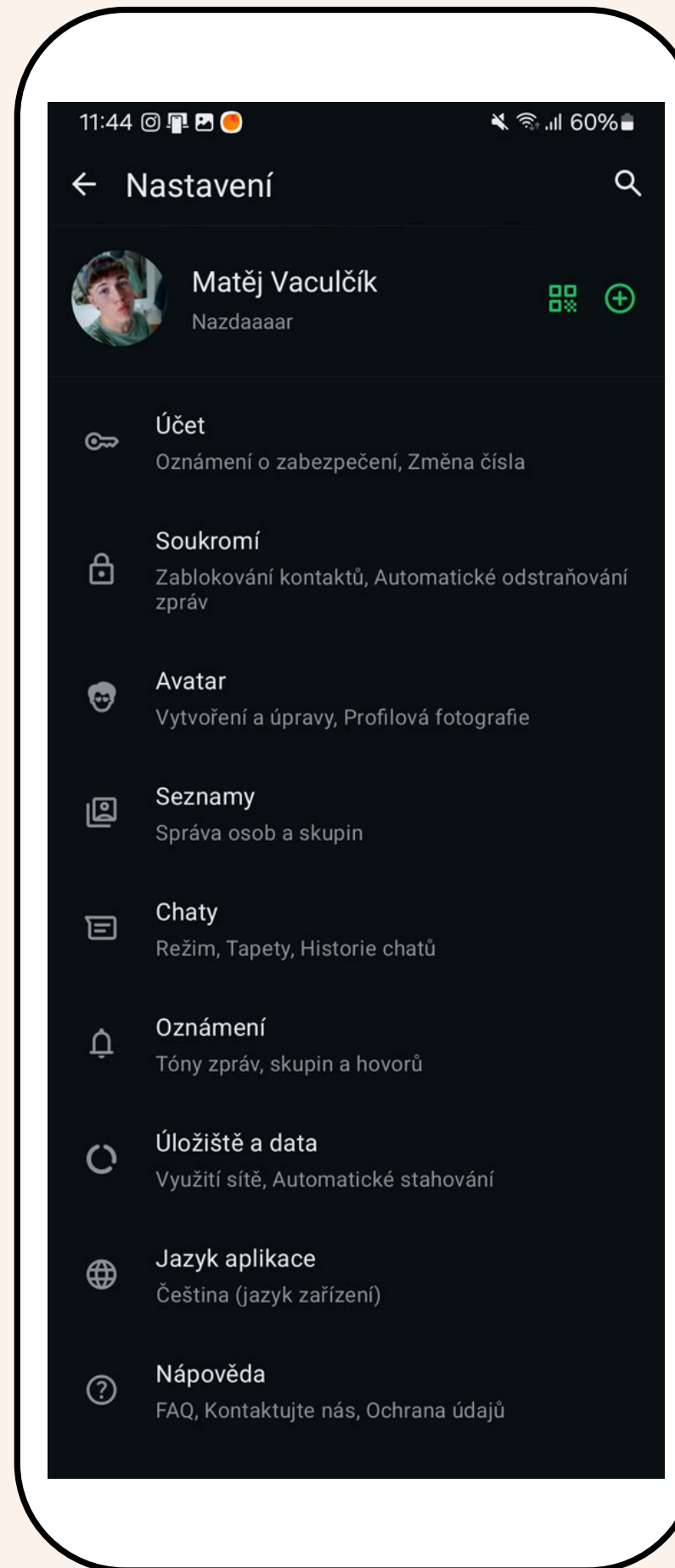
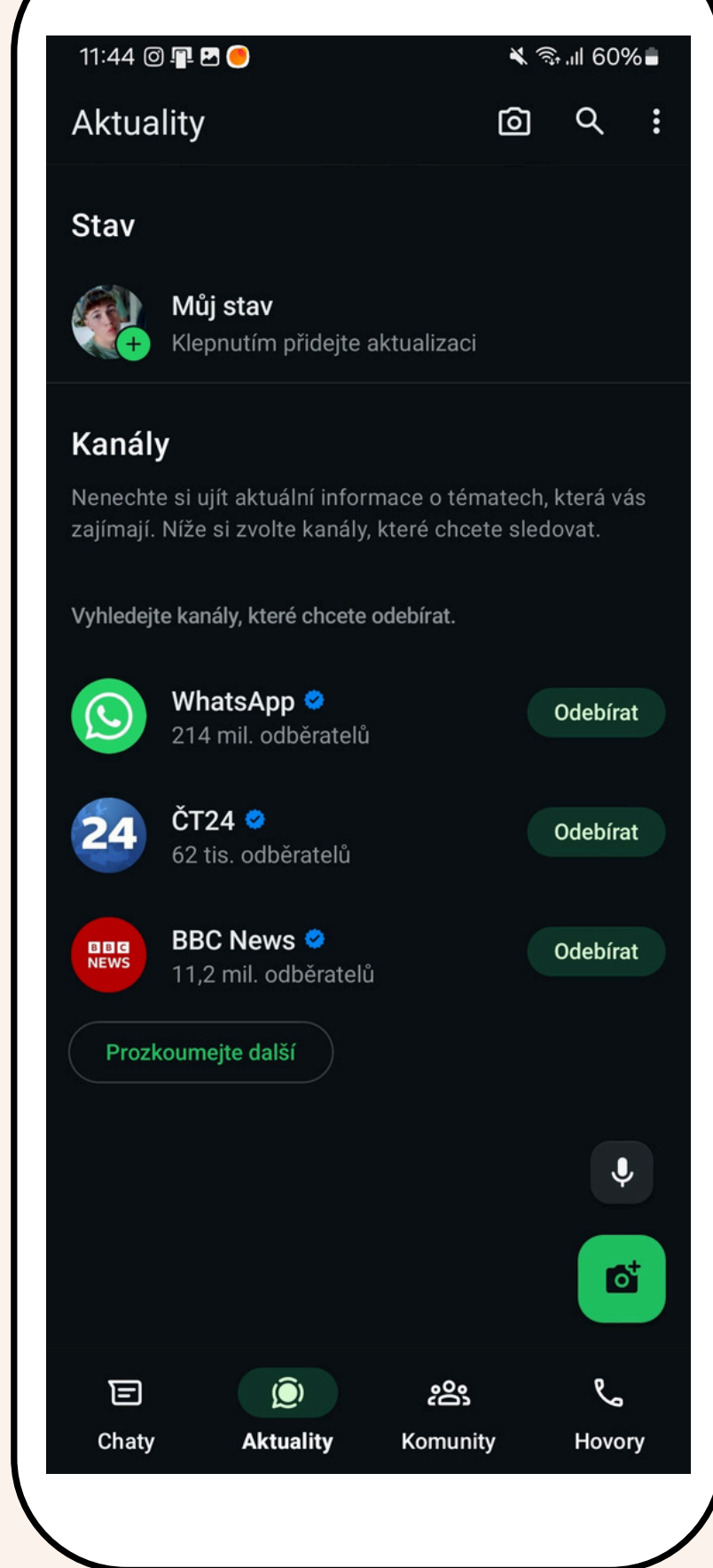

Onfine



WhatsApp

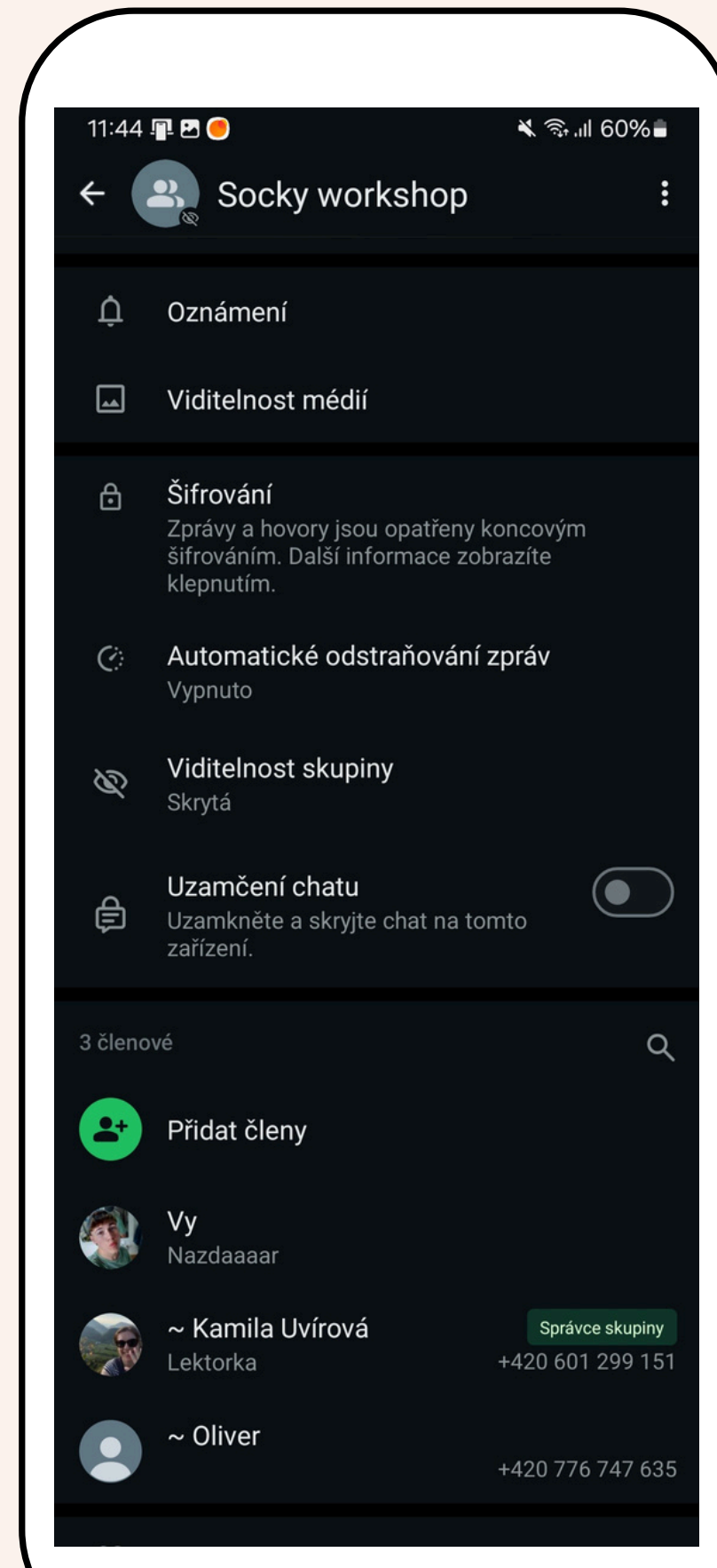
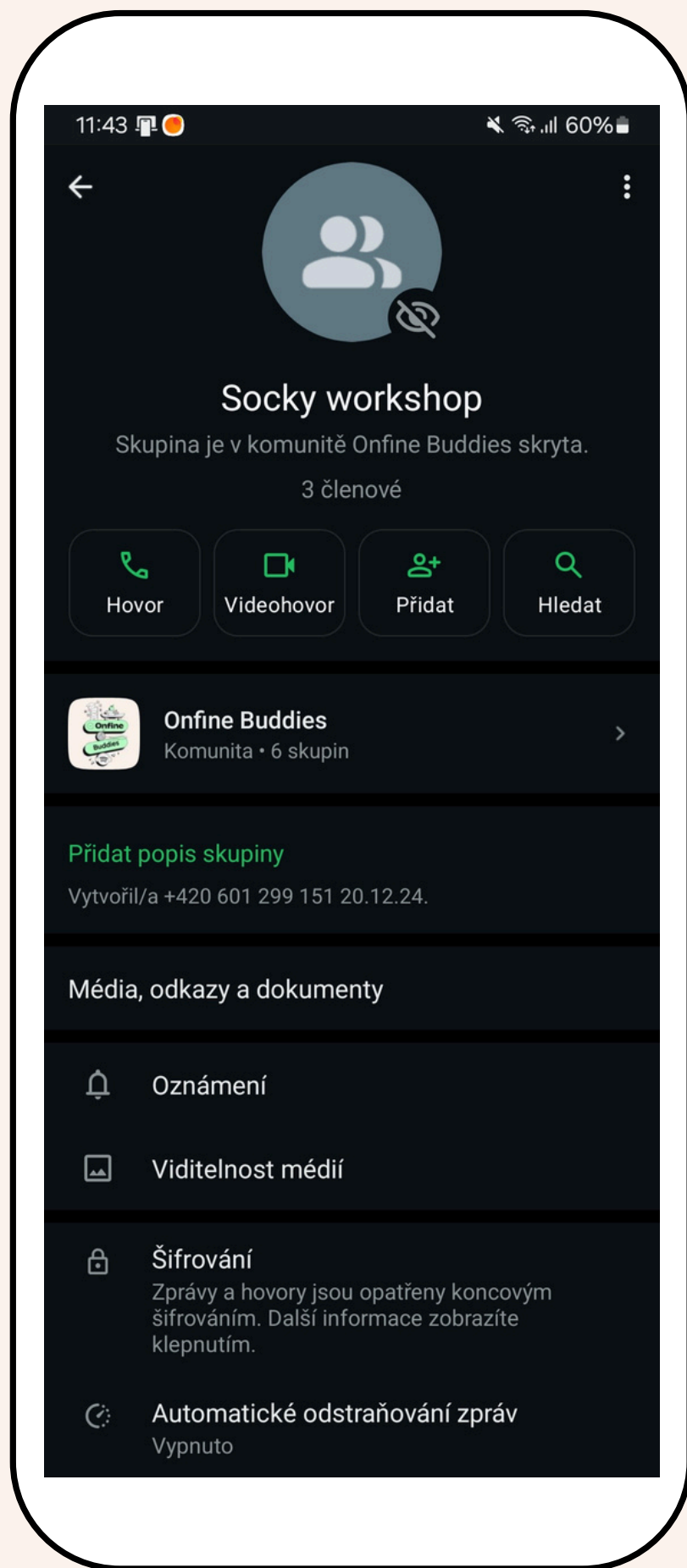

Onfine



WhatsApp

Online

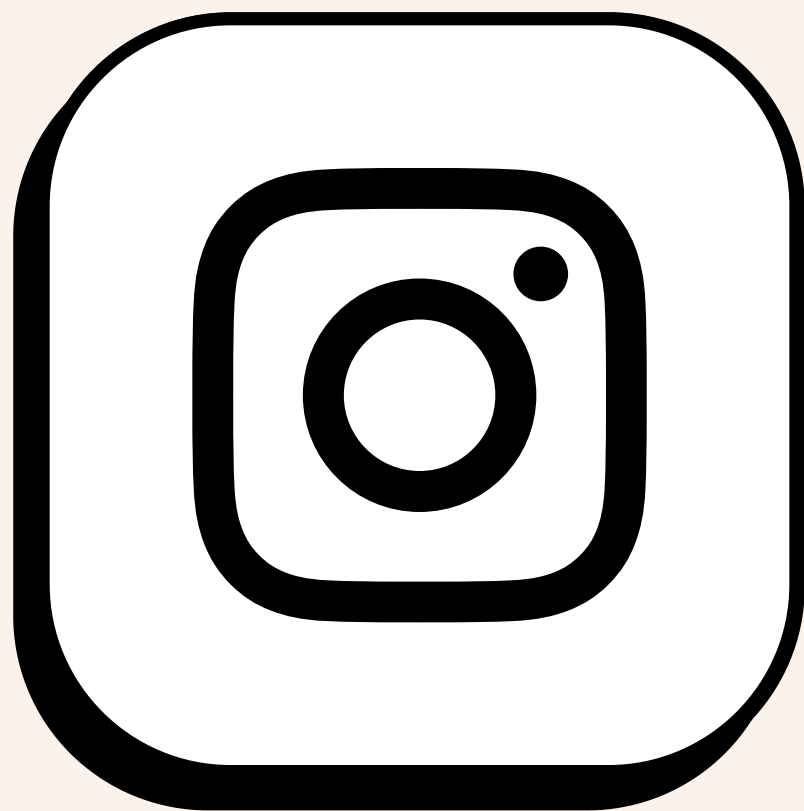

Instagram

Online

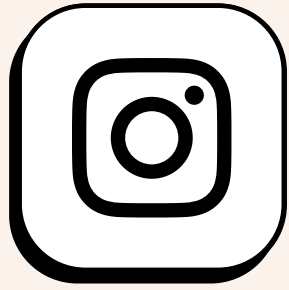

Instagram



Onfine

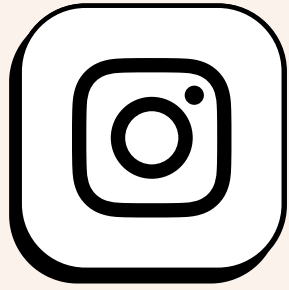

Instagram

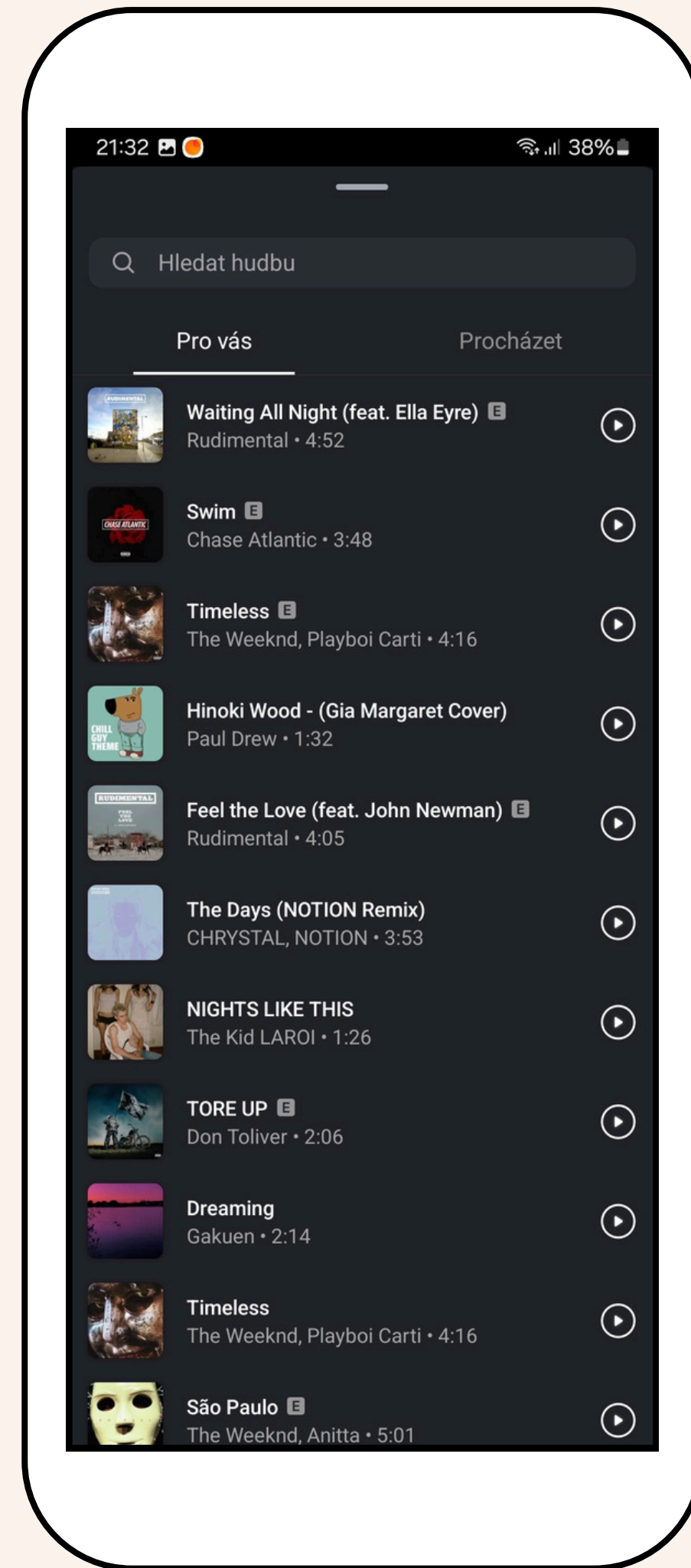
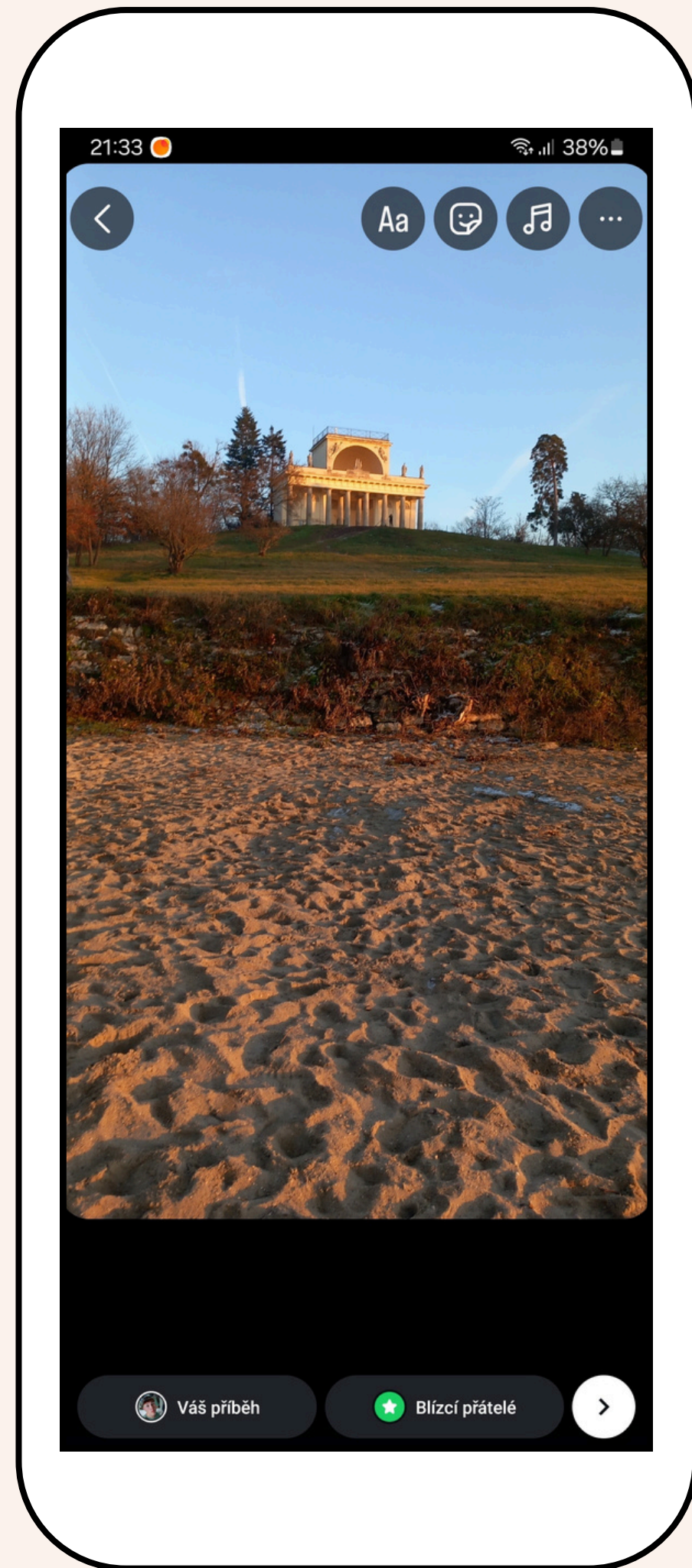
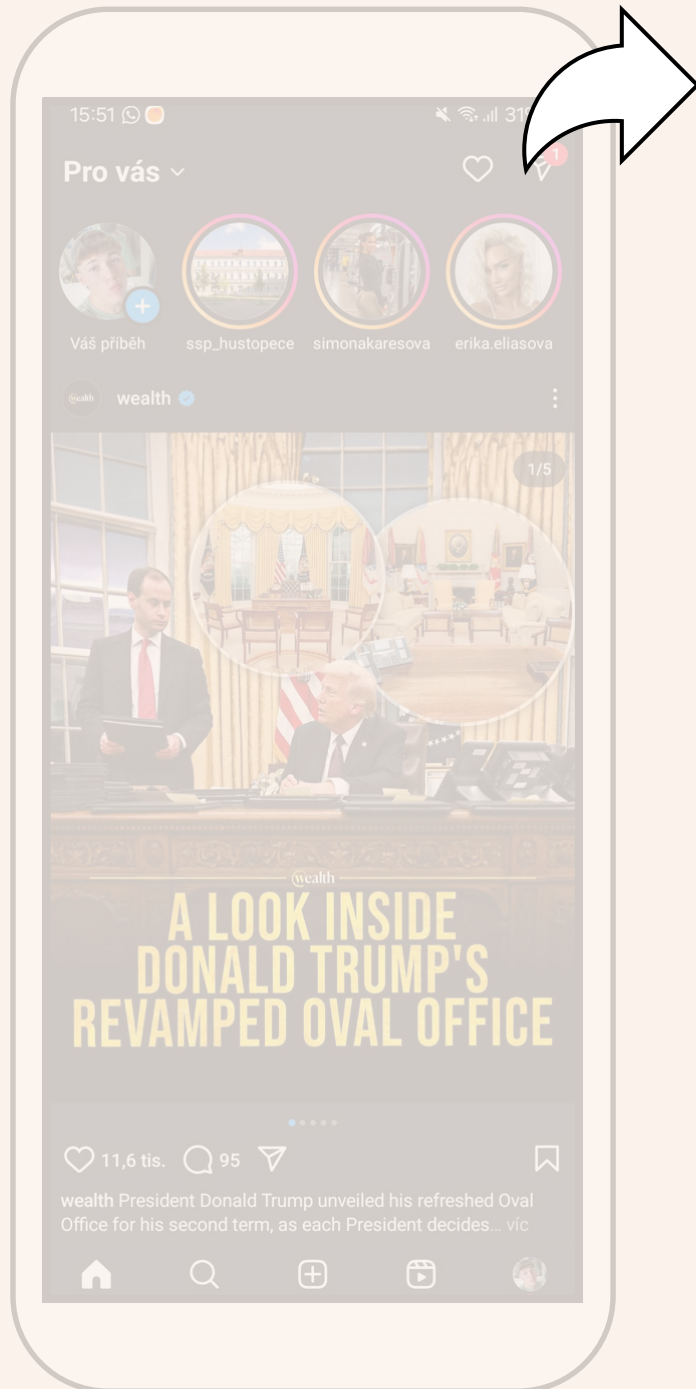

Onfine

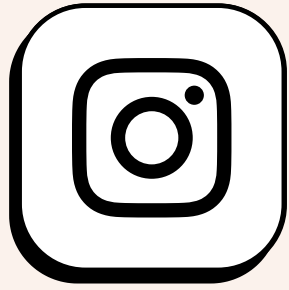

Instagram

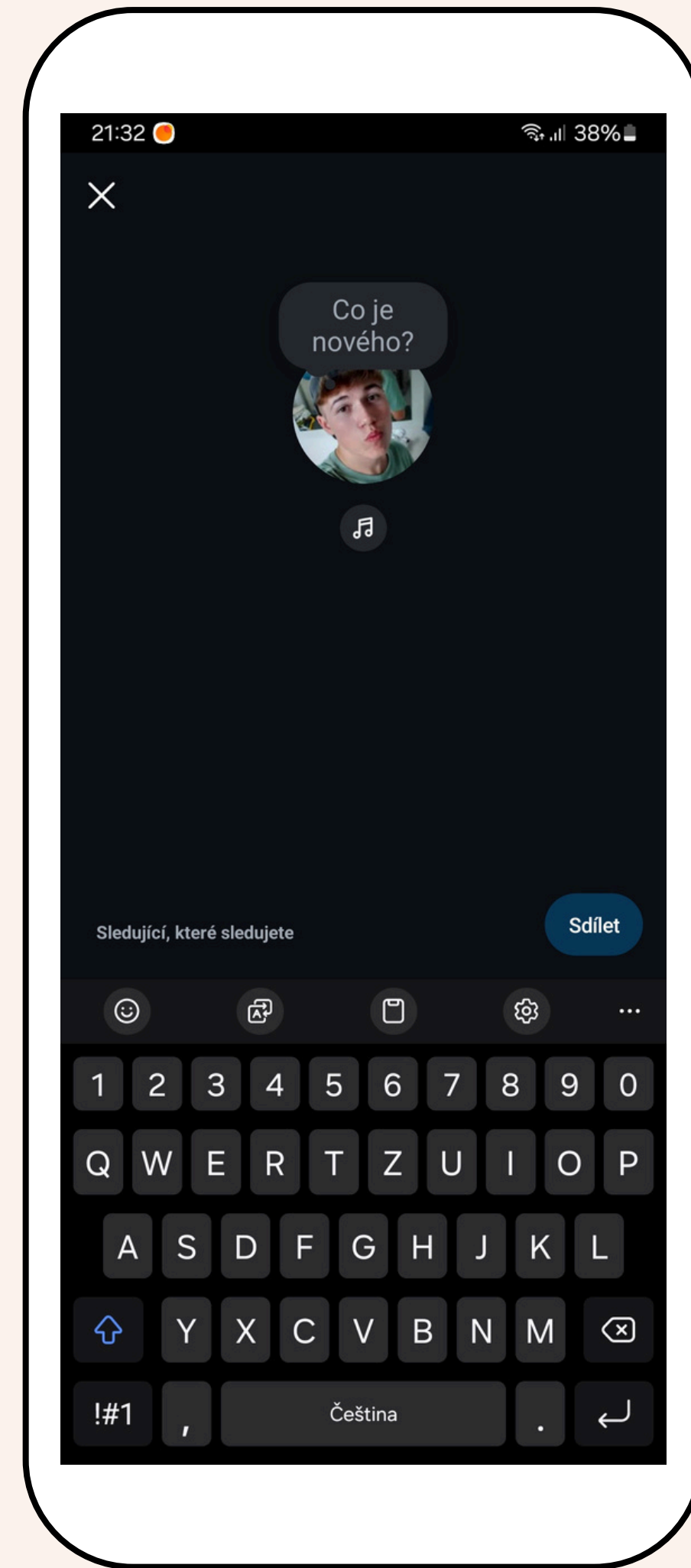
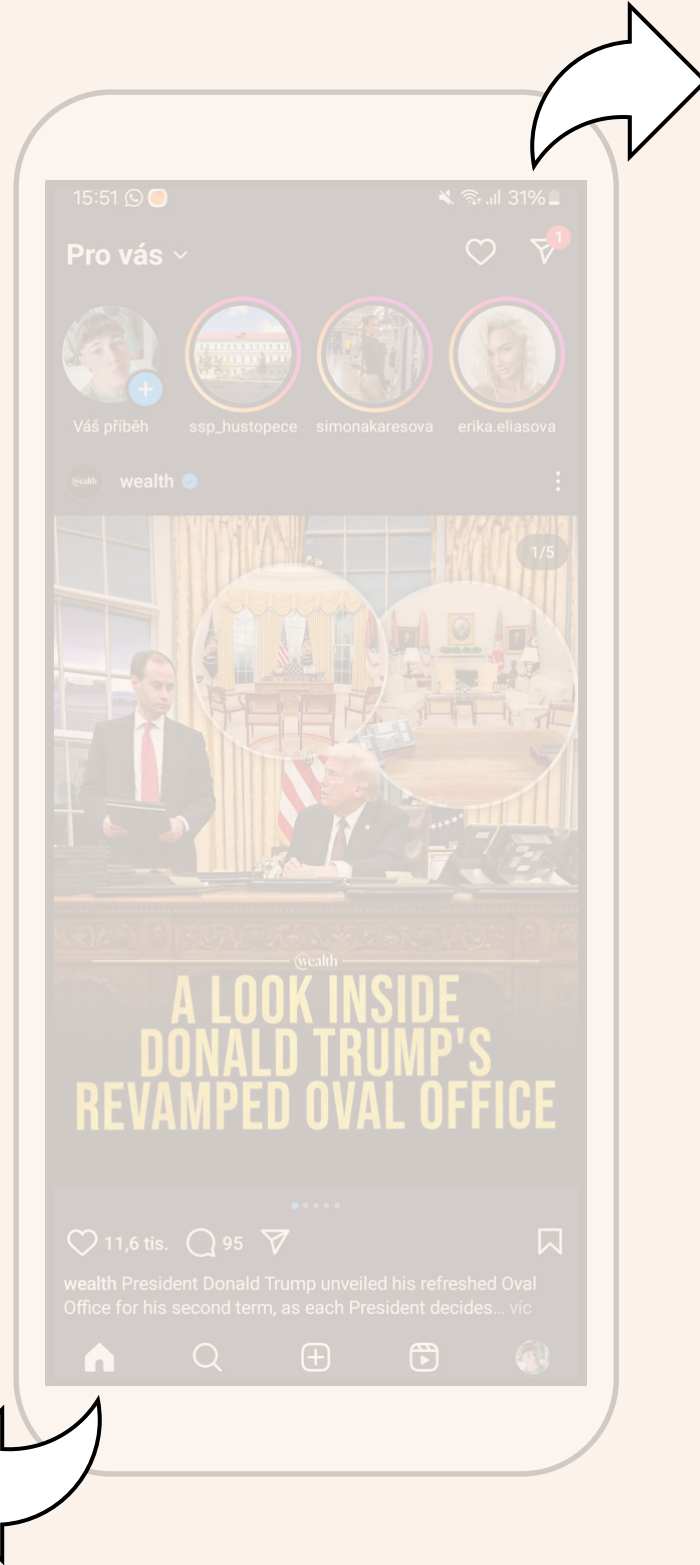
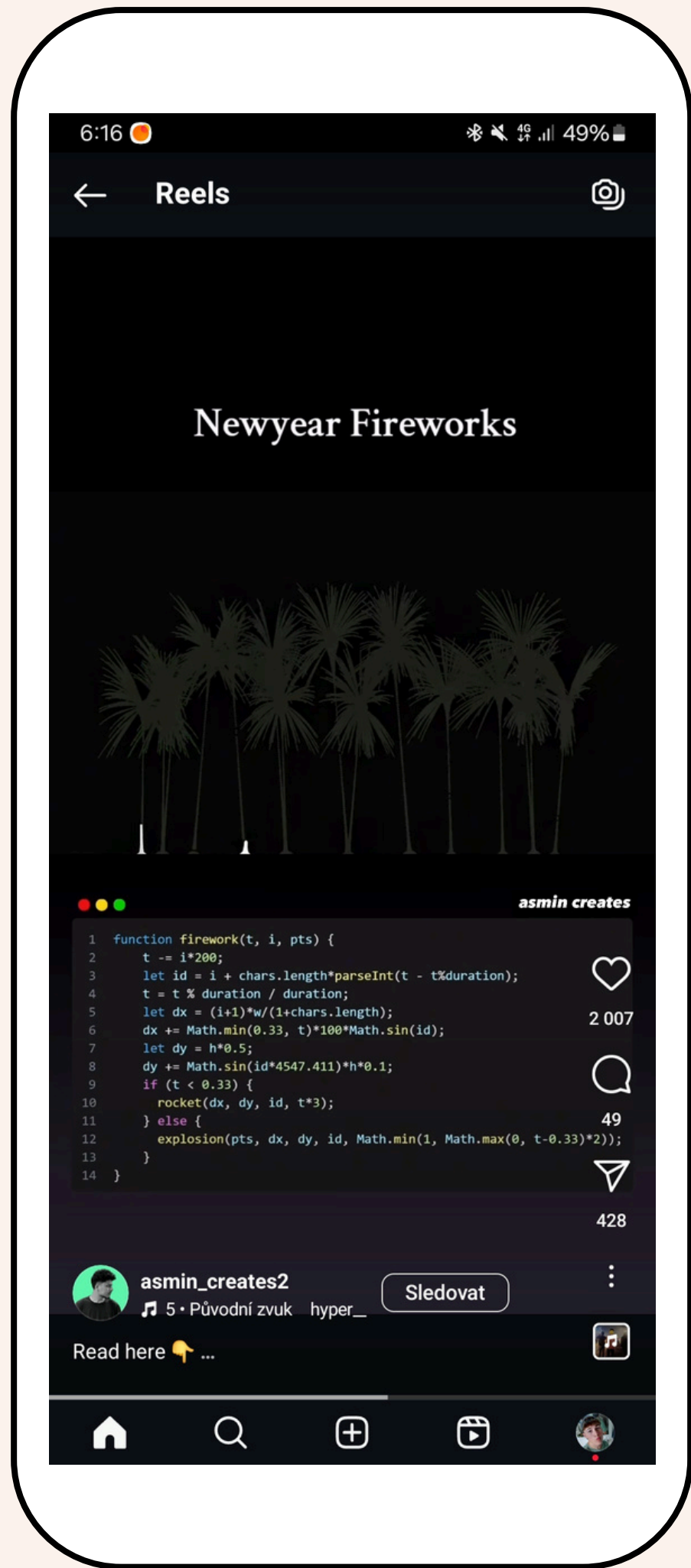

Online

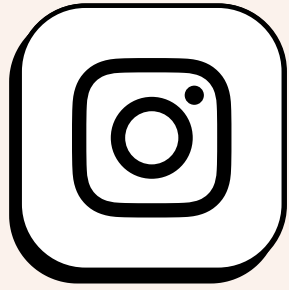

Instagram

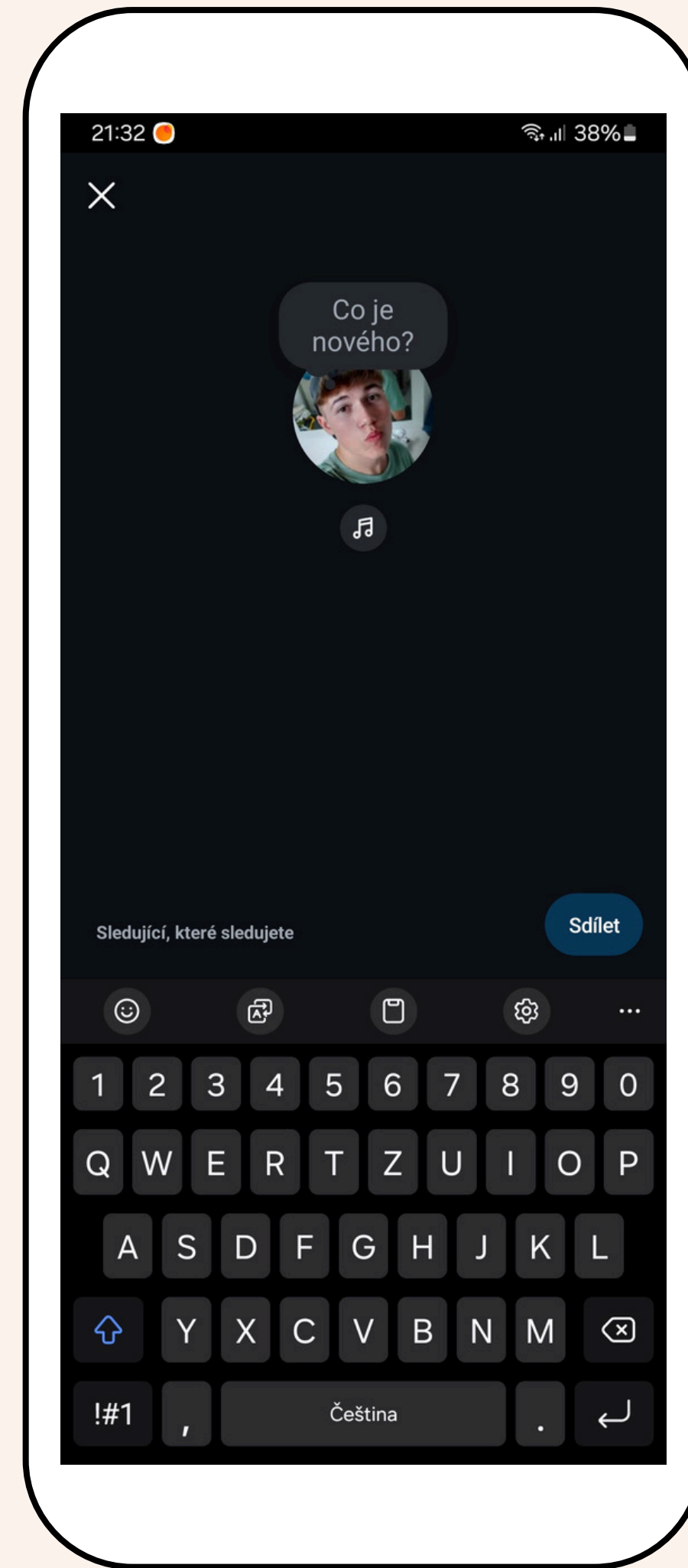
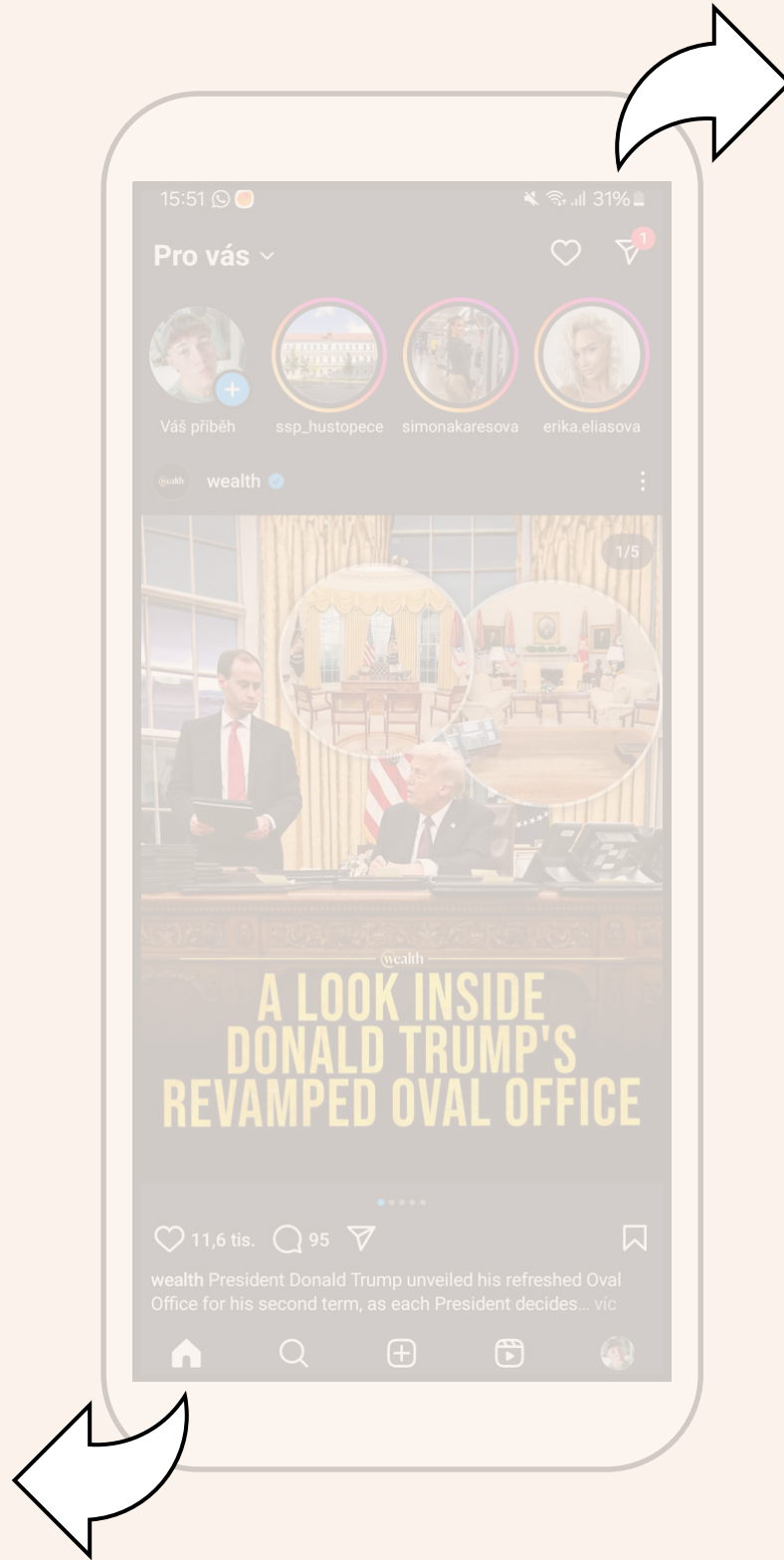
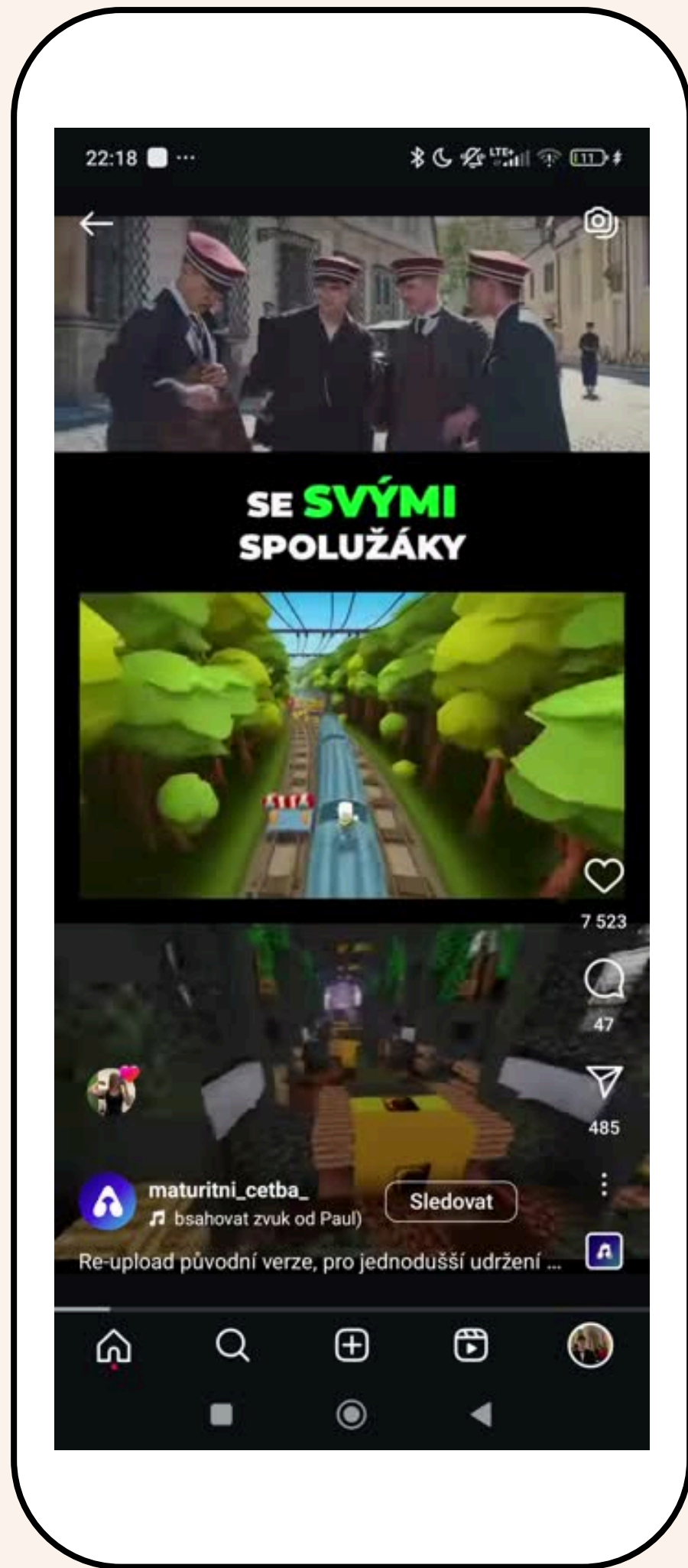

Online

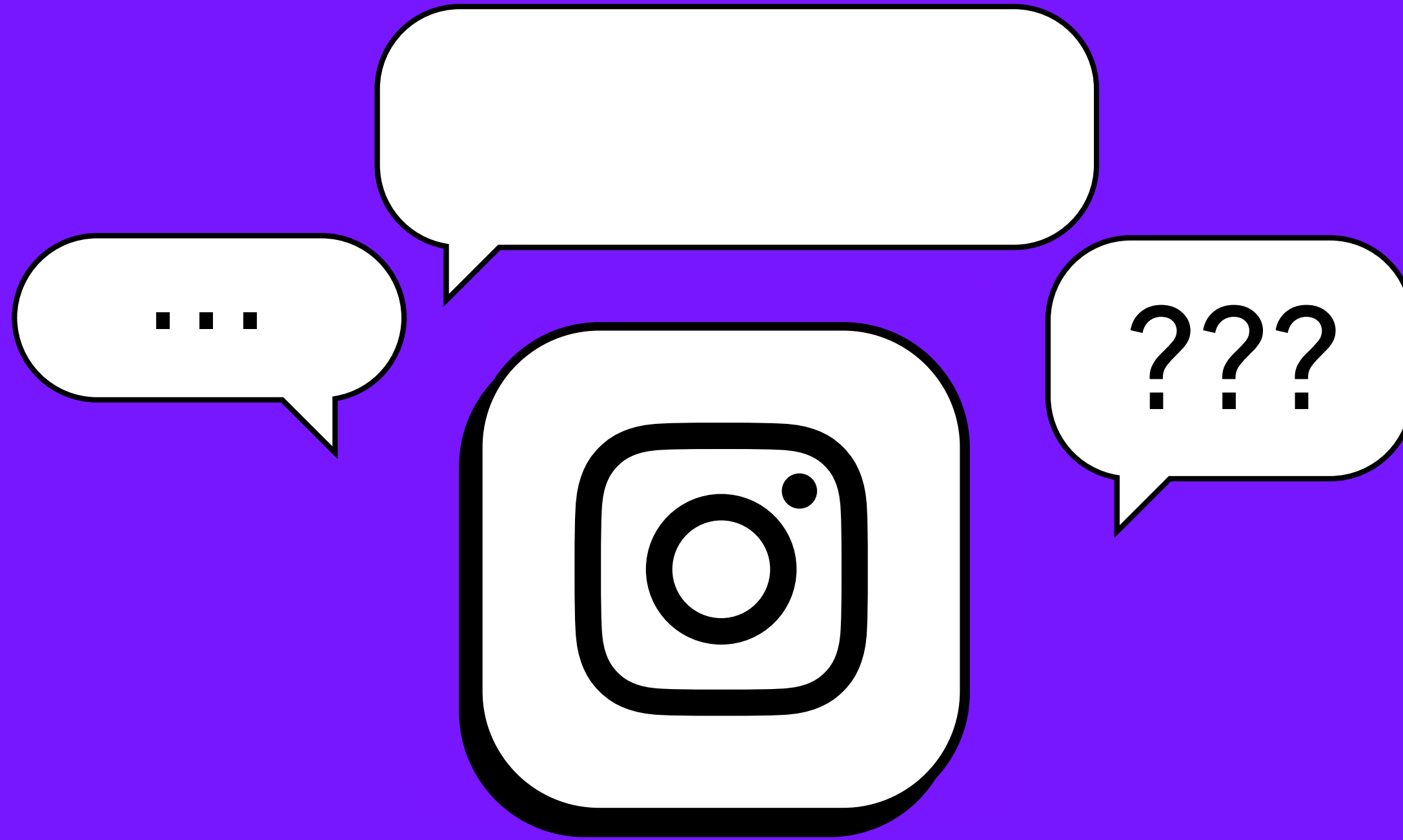

Instagram

Online

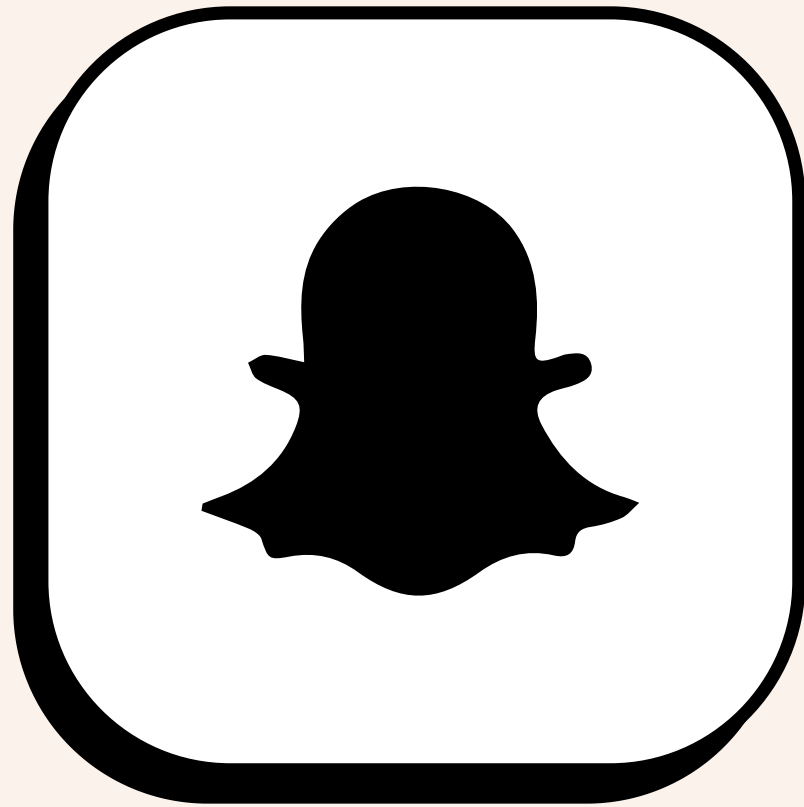

Snapchat

Online

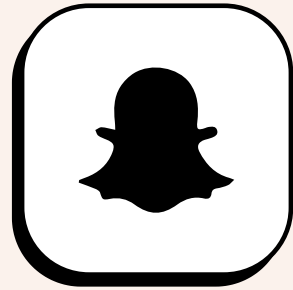

Snapchat

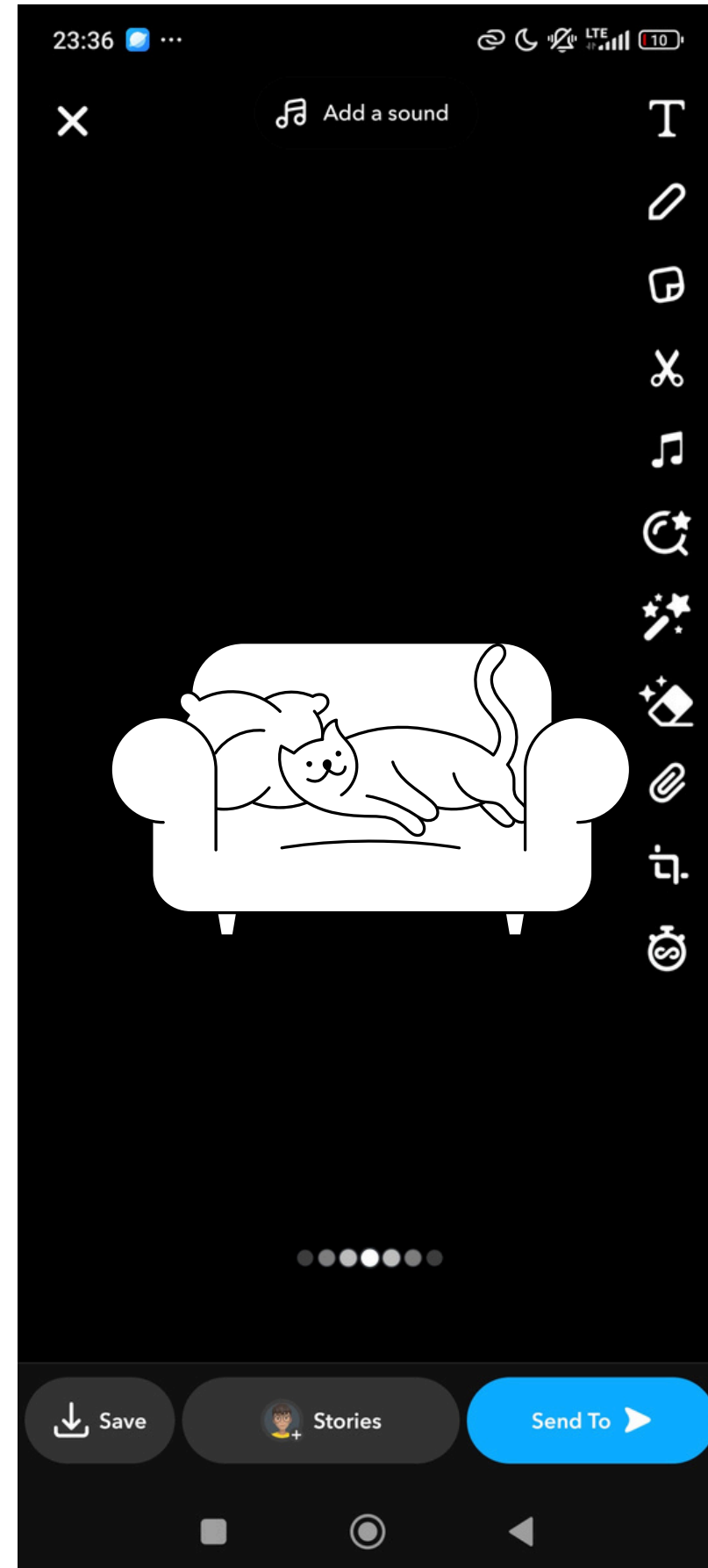
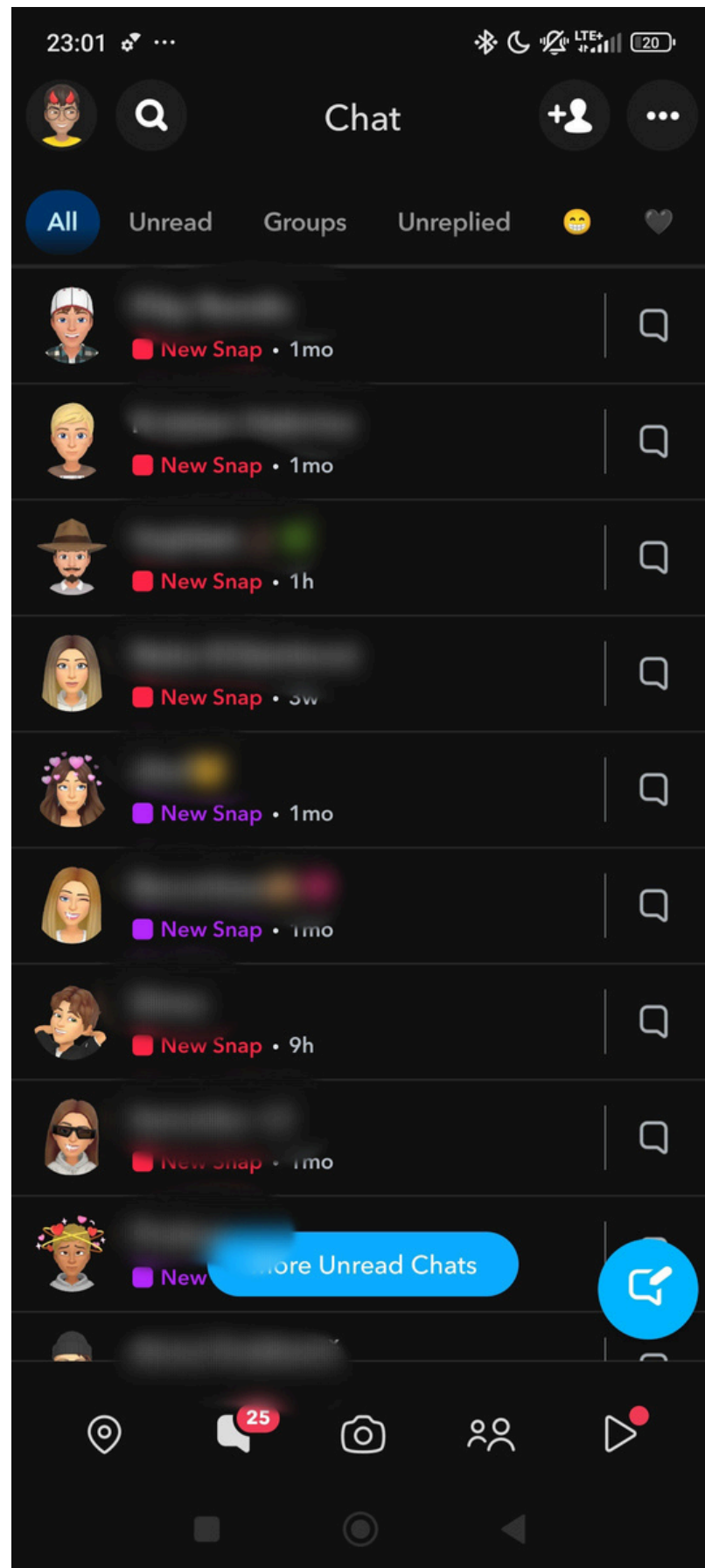

Online

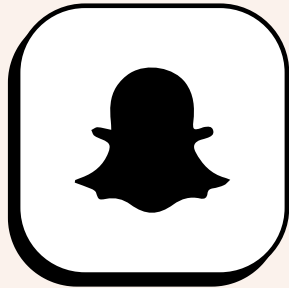

Snapchat

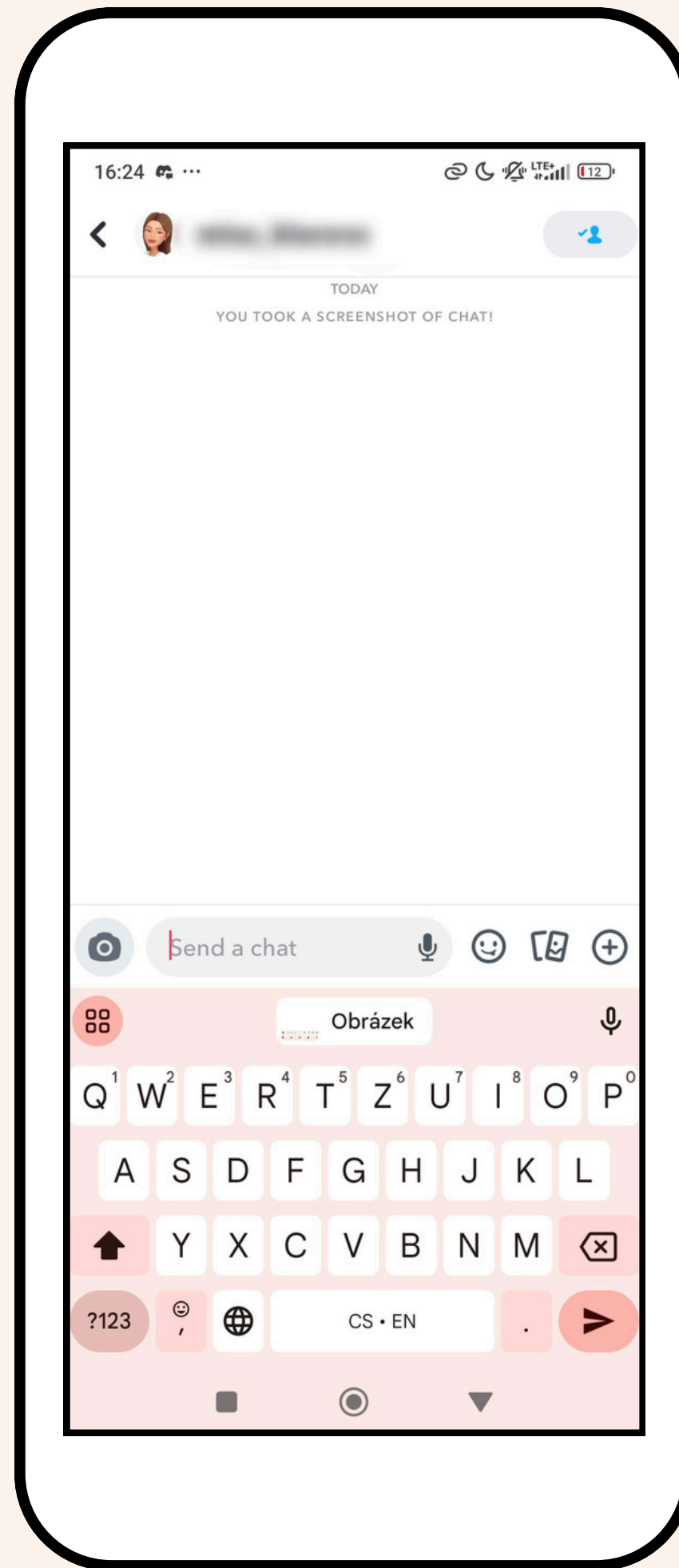
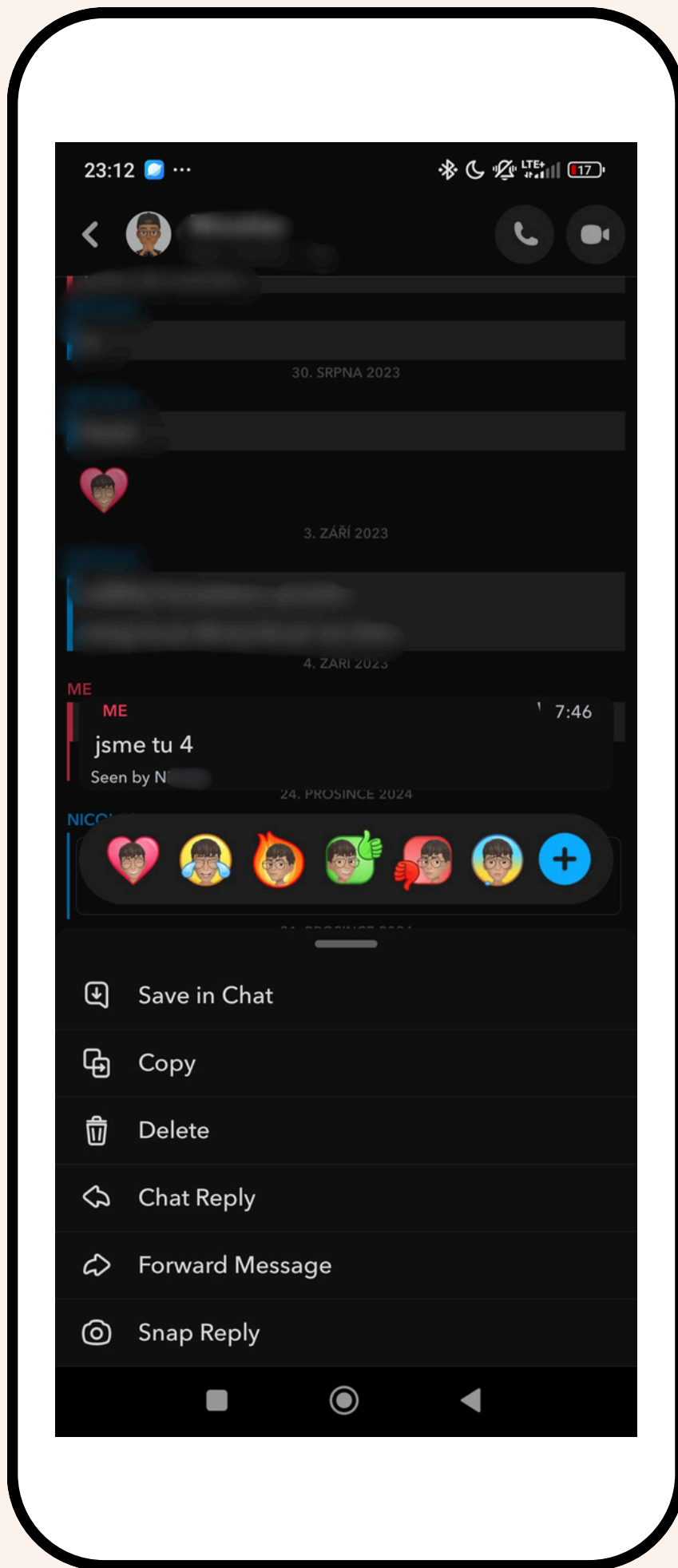

Online

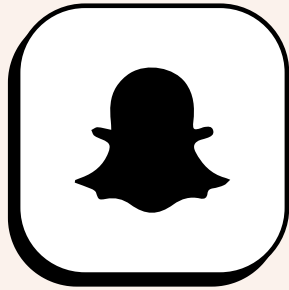

Snapchat

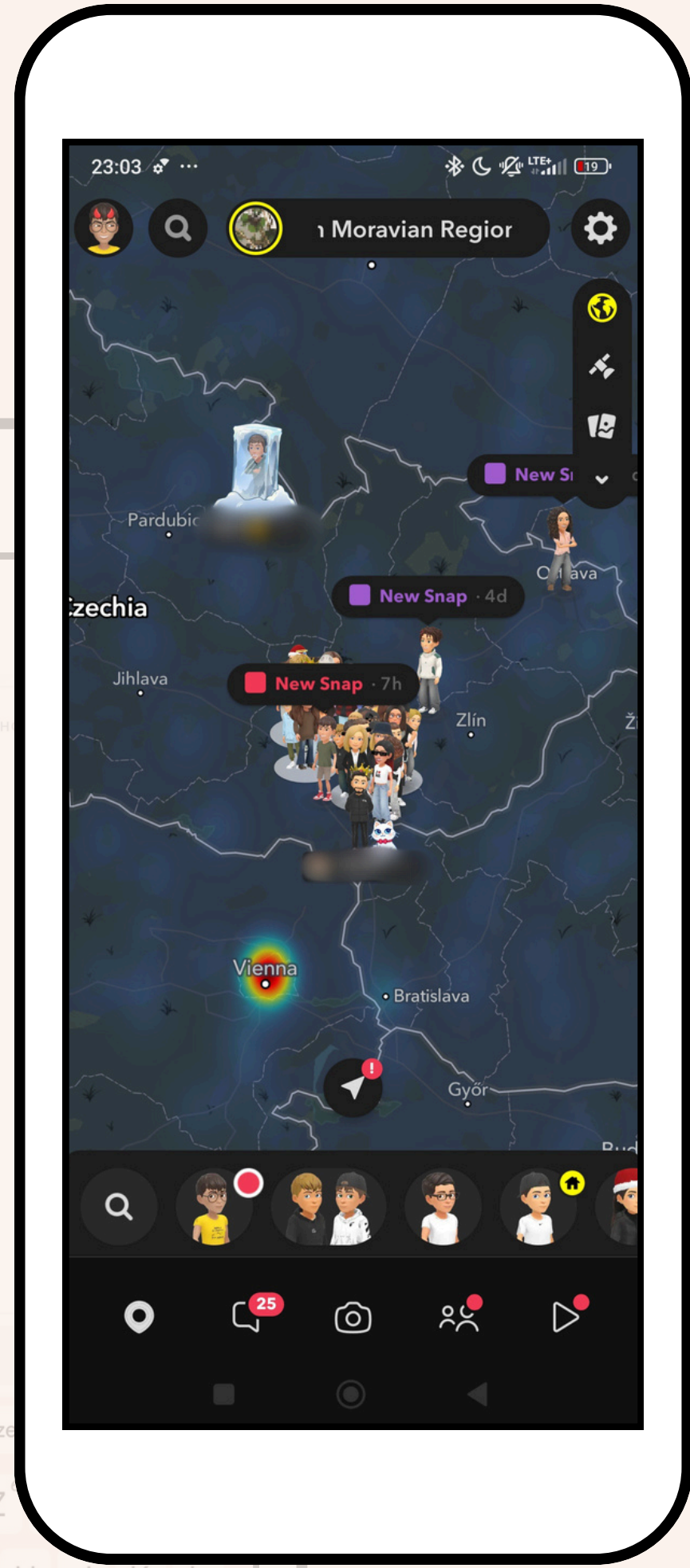
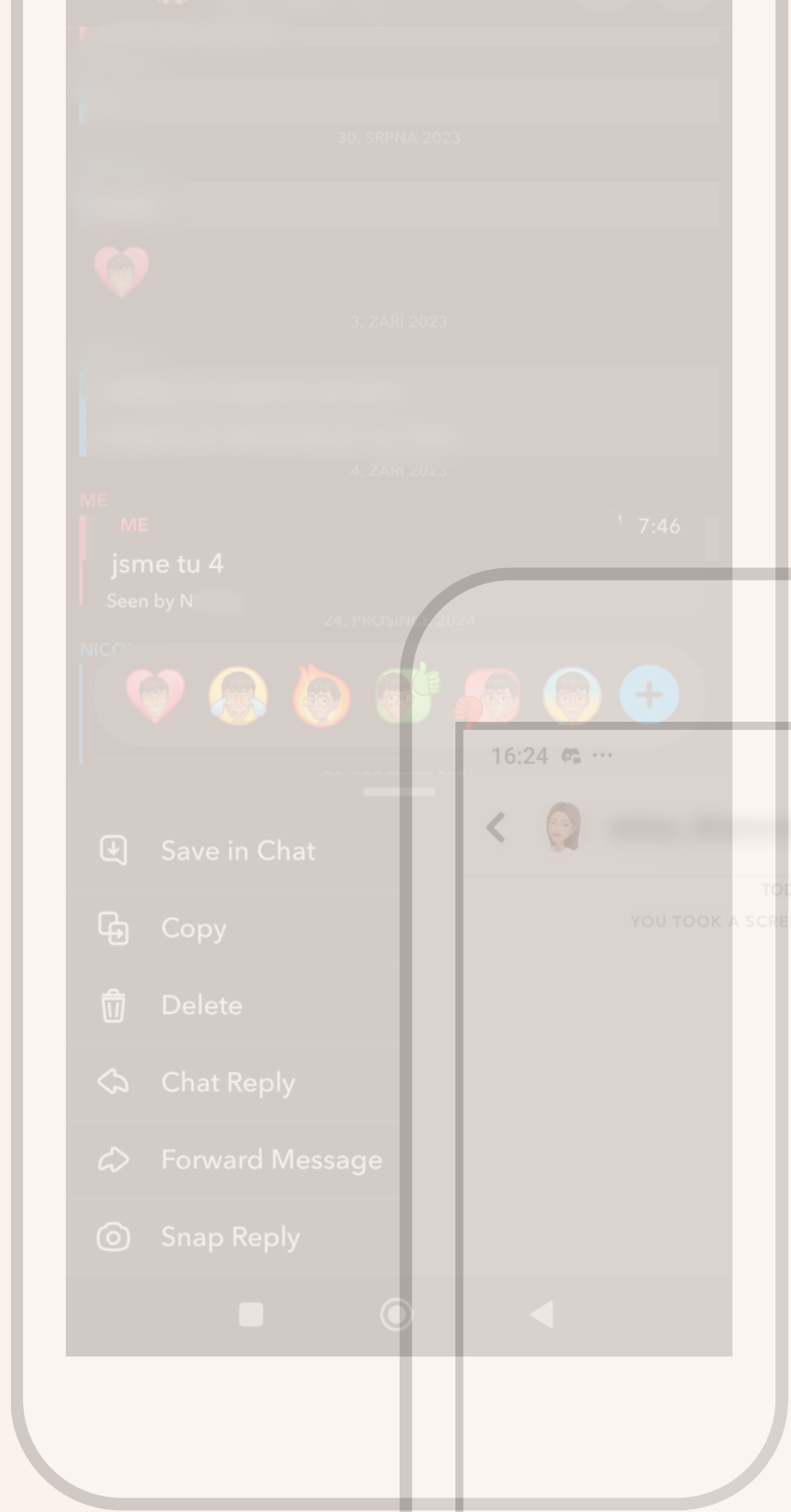

Online

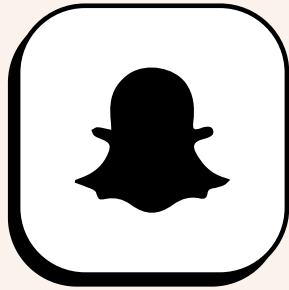

Snapchat

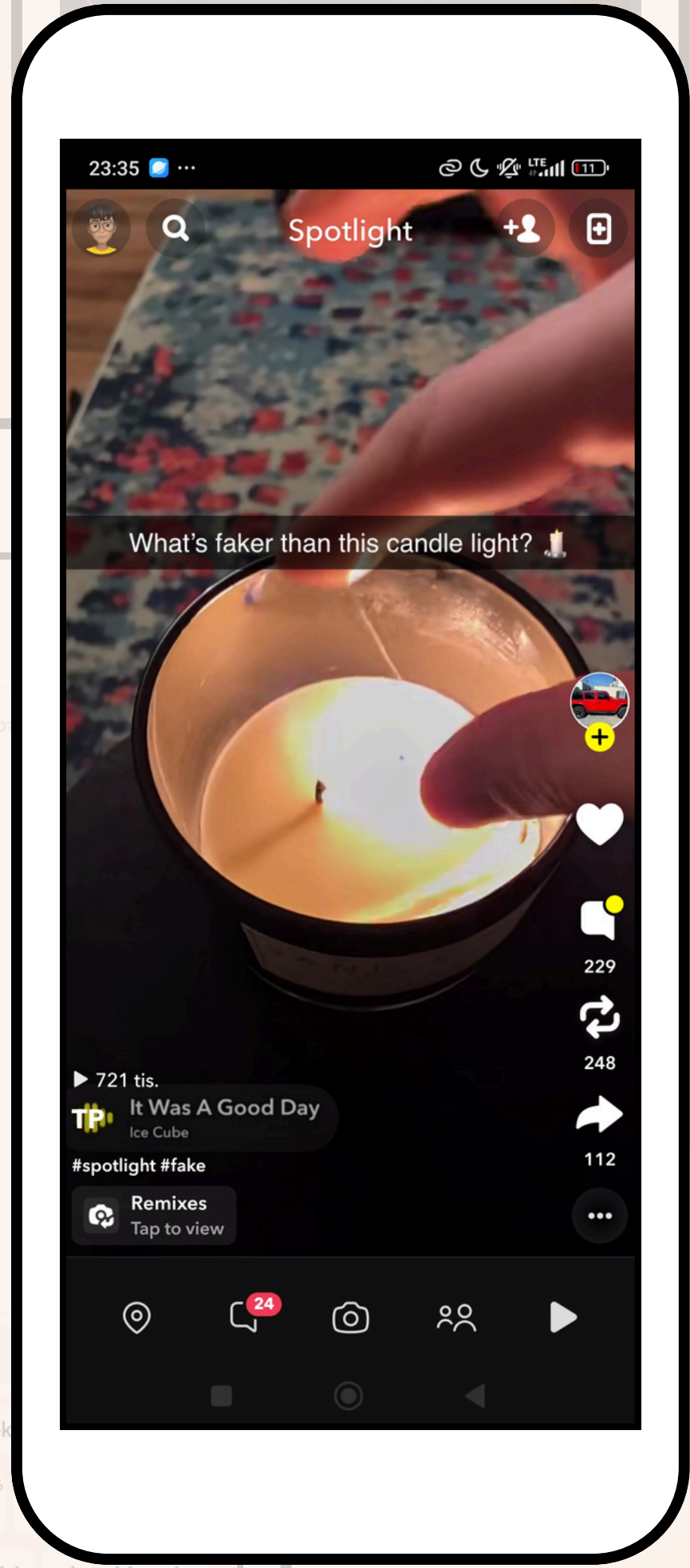
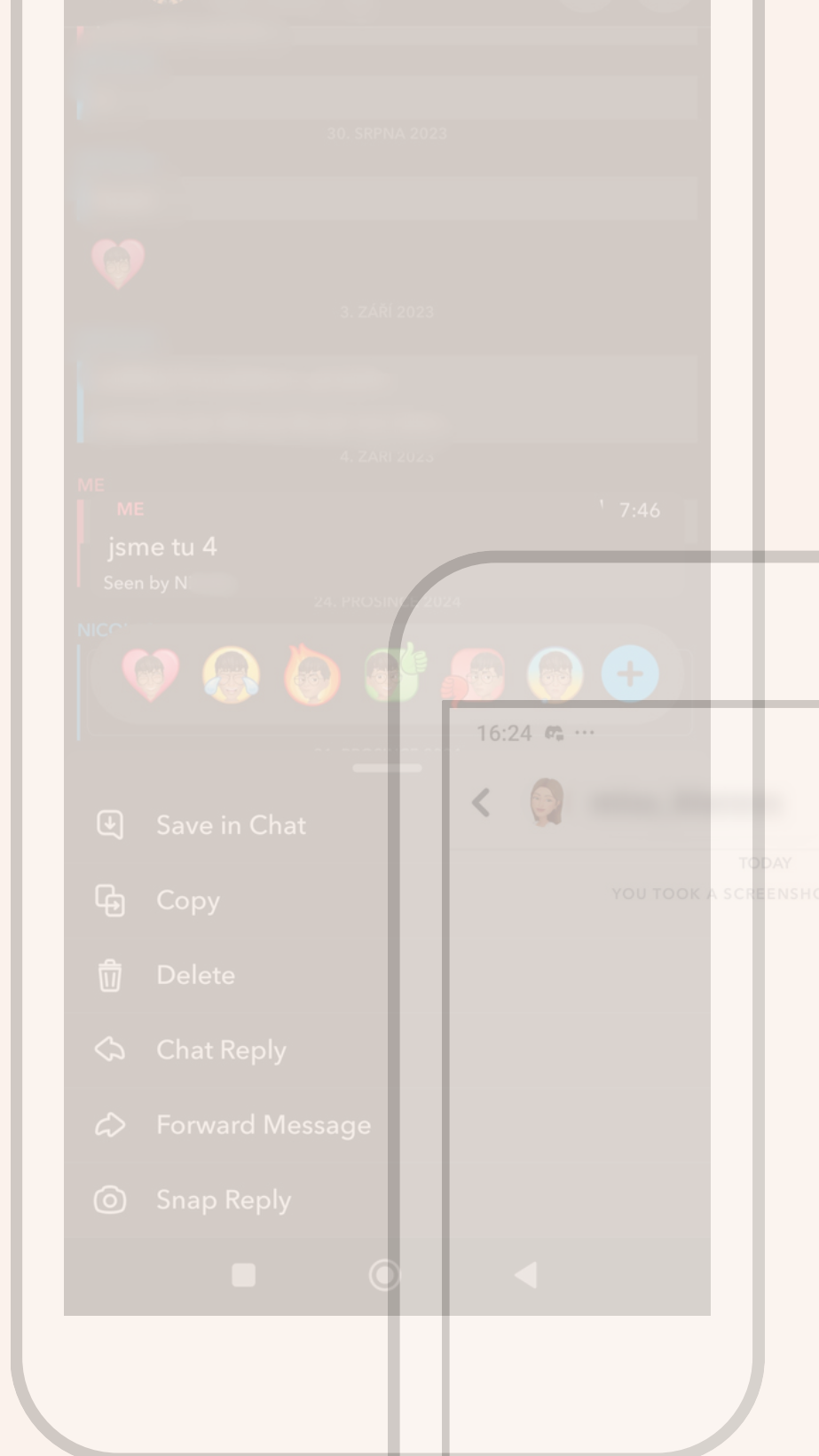

Online

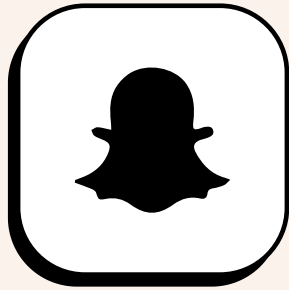

Snapchat

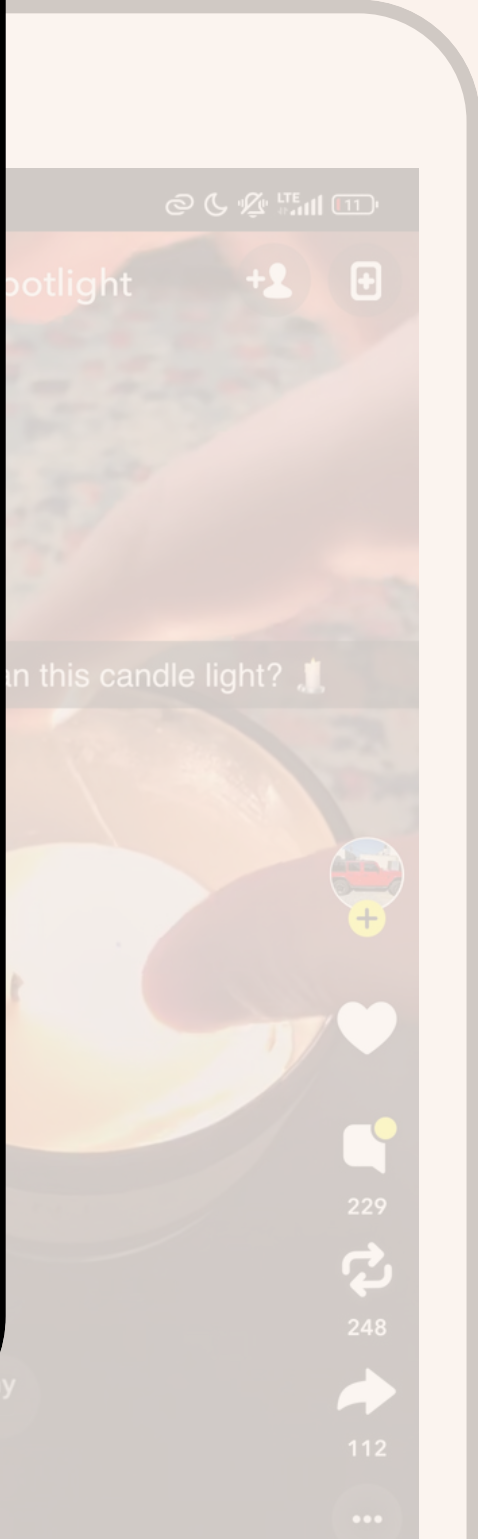
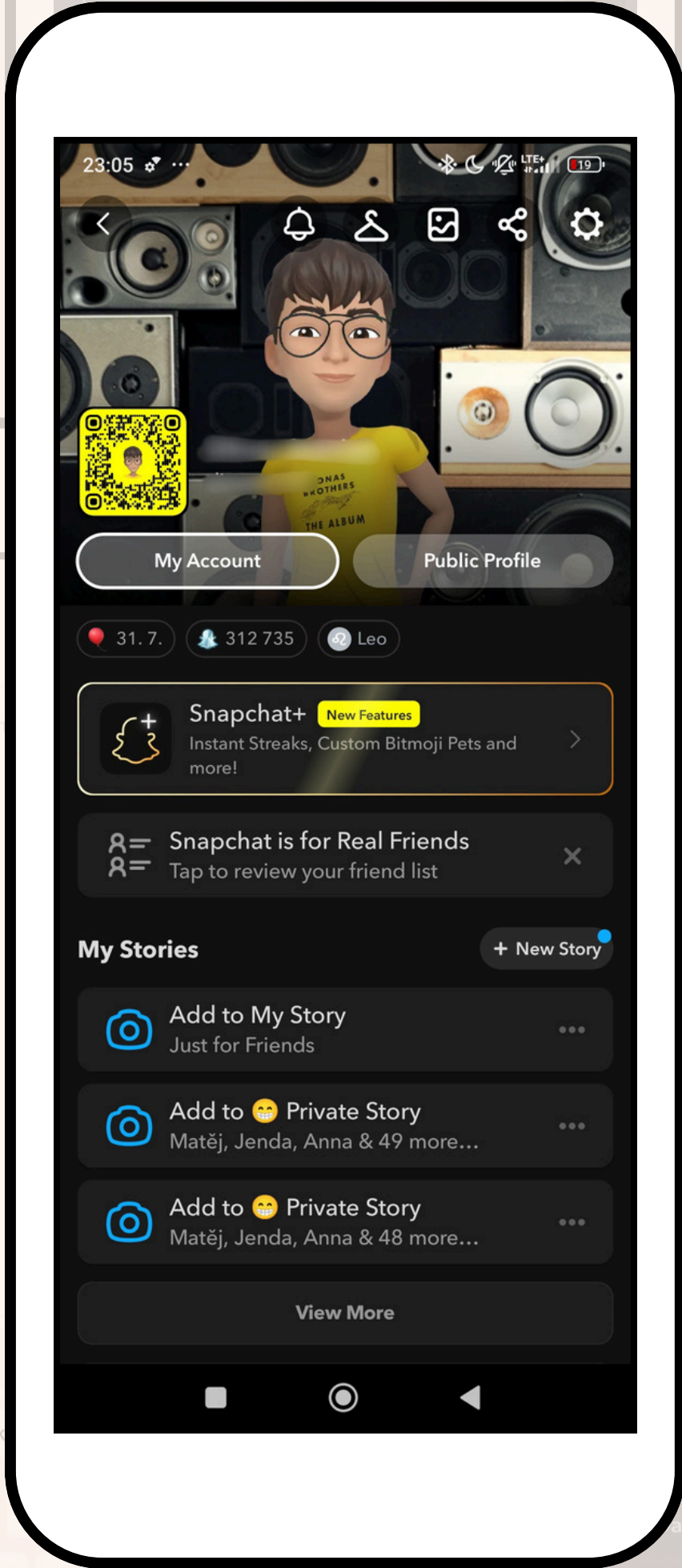
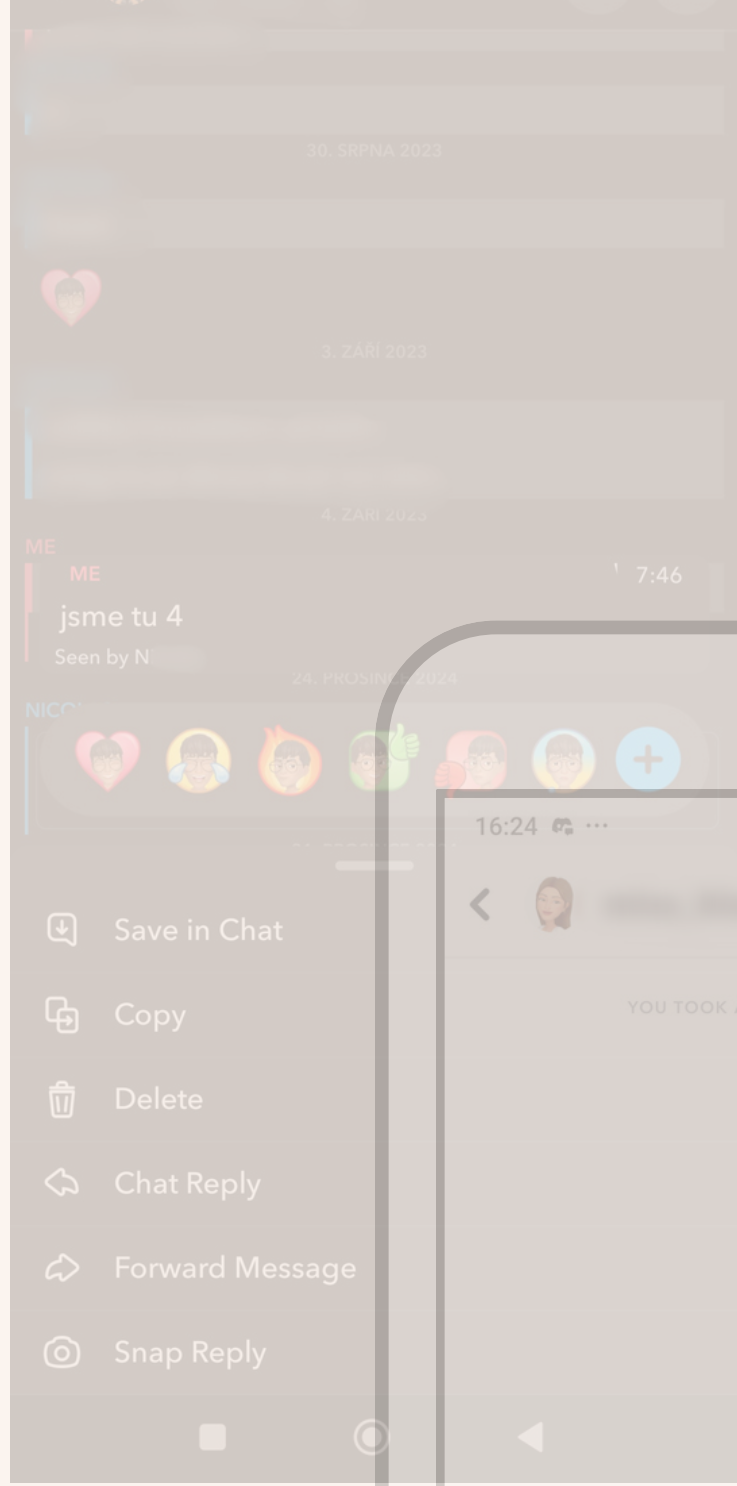

Online

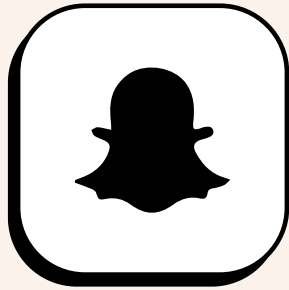

Snapchat

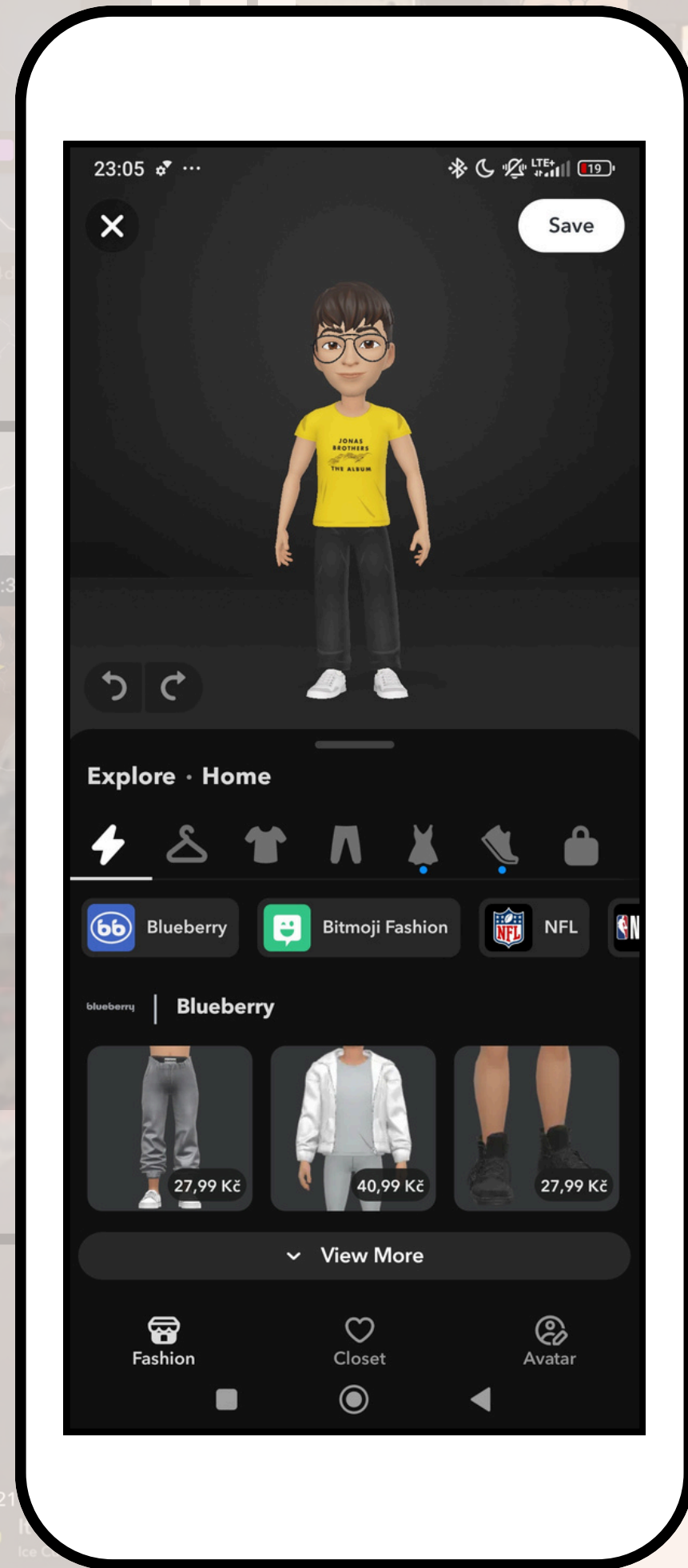
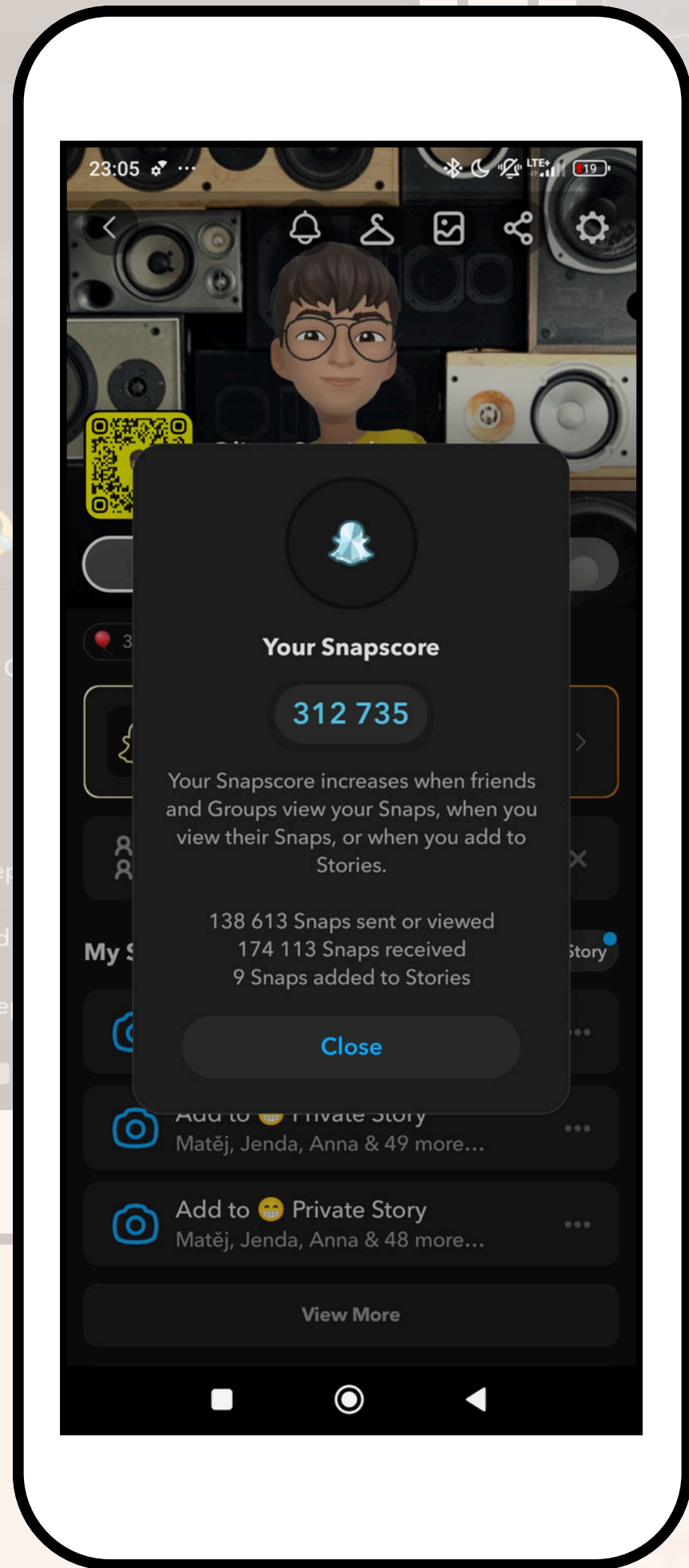

Online

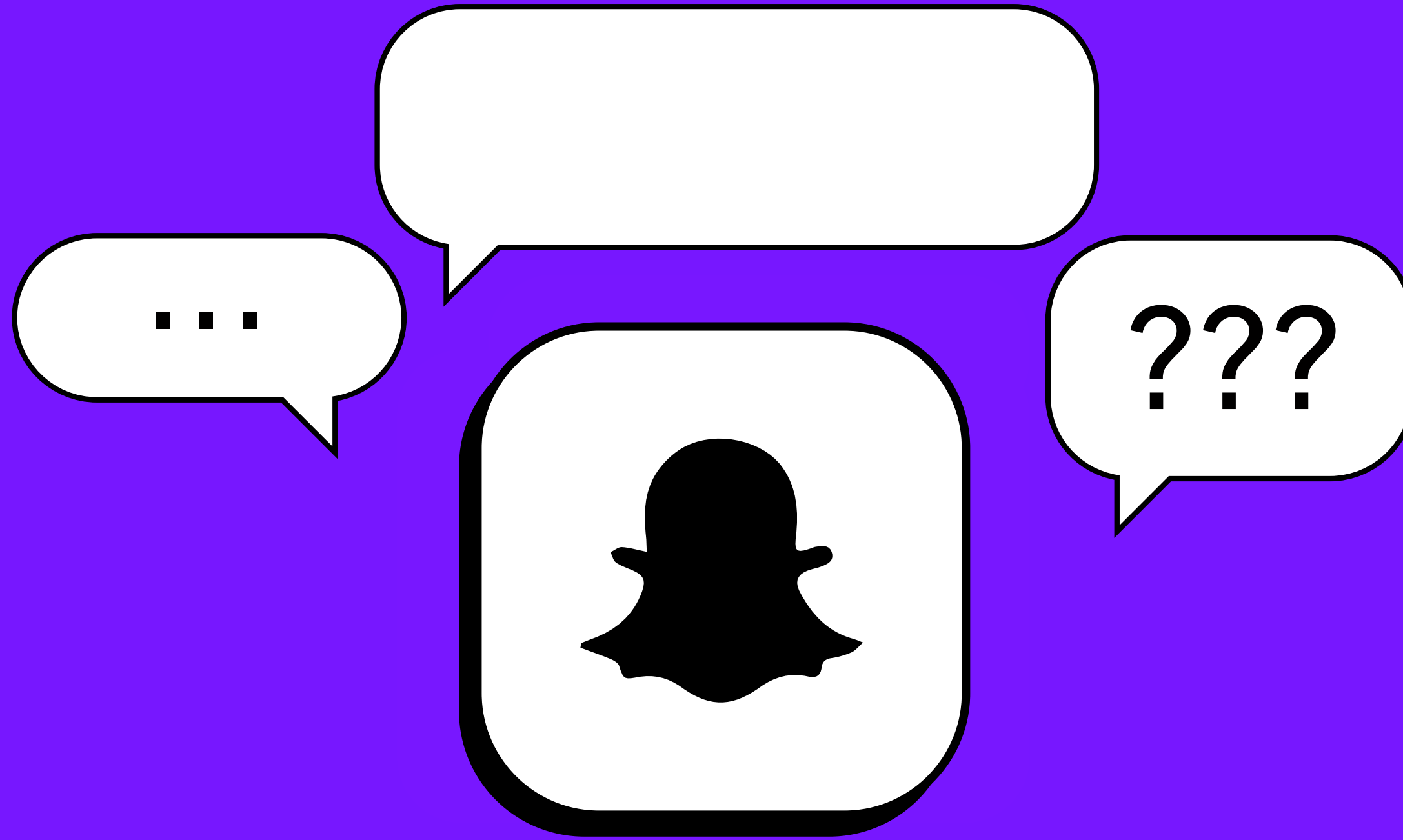

Snapchat

Online

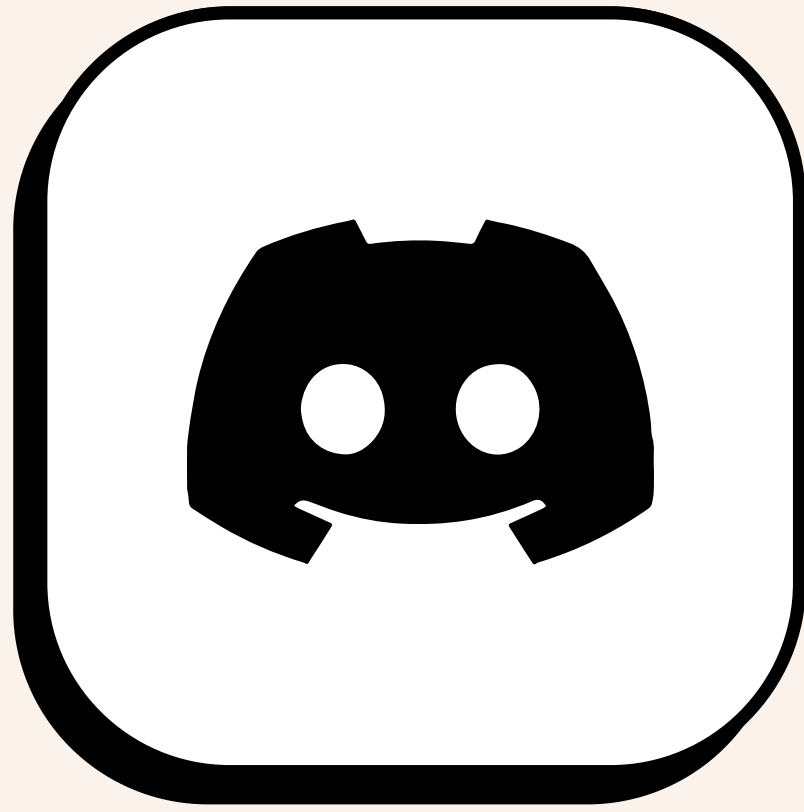

Discord

Online

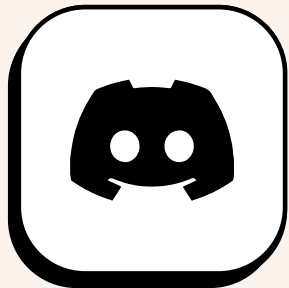

Discord

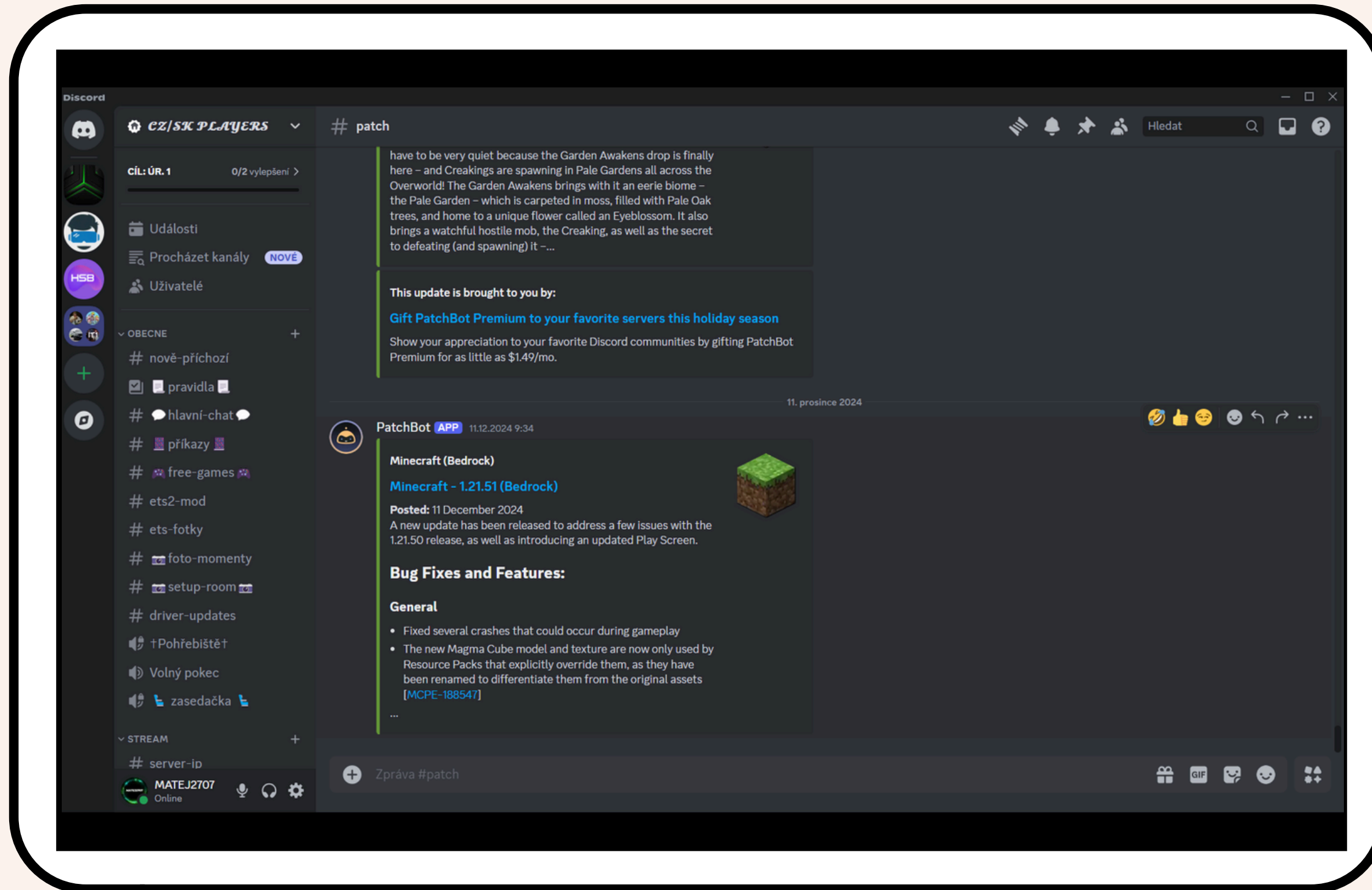

Online

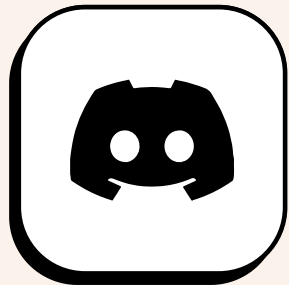

Discord

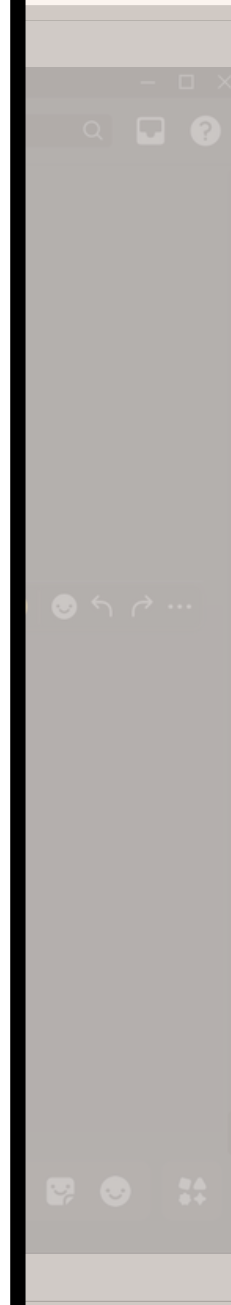
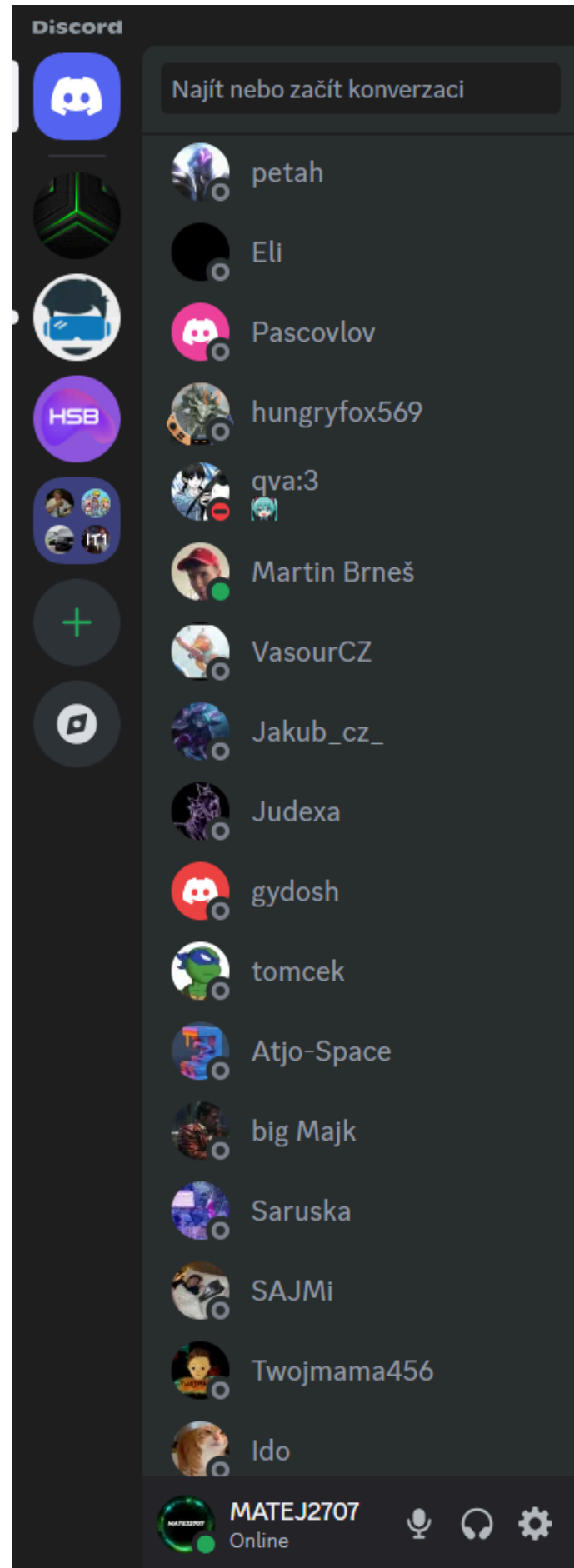
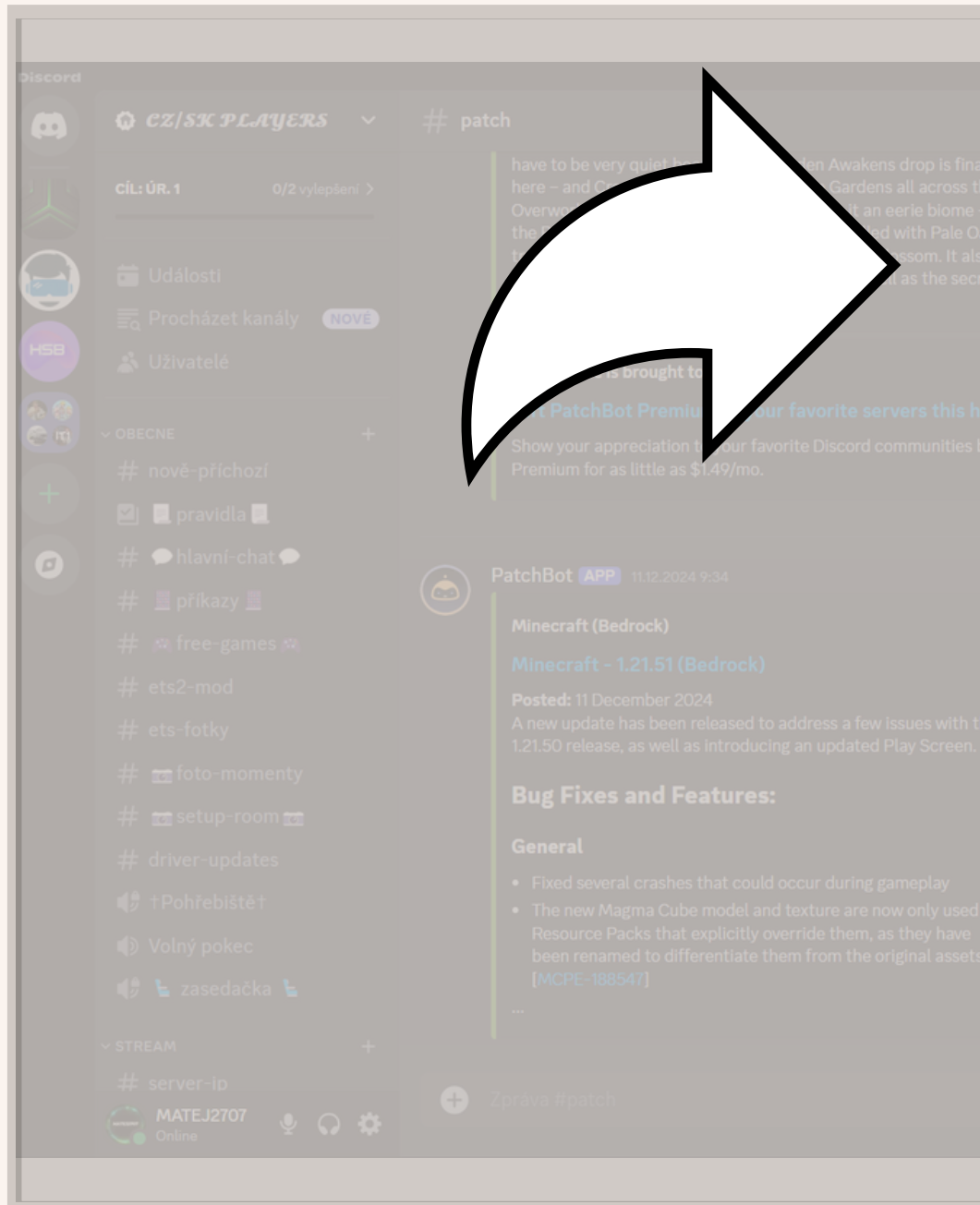

Online

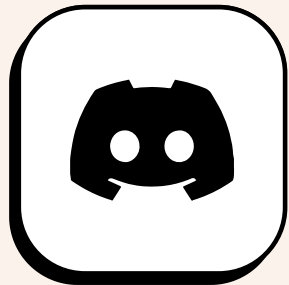

Discord

- # cvičení-matematiky-1
- # cvičení-matematiky-2
- # dějepis
- # ekologie-a-biologie
- # elektro-měření
- # elektrotechnika
- # fyzika
- # hardware
- # informační-a-komunikač...
- # matematika
- # programování-a-vývoj-a...
- # programové-vybavení

PŘEDMĚTY 2.ROČNÍK

- # elektronika
- # ict
- # občanská-nauka
- # programové-vybavení
- # matematika
- # číslicová-technika
- # operační-systémy
- # fyzika

ICT - KANDIDÁTNÍ KLÍČ

Klíče

Uvažujme následující tabulku studentů, která je v relaci s tabulkou studijní_obory.

id	id_ob	jméno	příjmení	obor
10	00125	Jan	Novák	S
11	00087	Petr	Mušík	S
12	00316	Markéta	Zpěváčková	S

Kandidátní klíče

28. listopadu 2024



Šimon Zeman 28.11.2024 20:03

ICT - ODKAZ NA TEAMS

https://teams.microsoft.com/l/team/19%3AAAMdCPIhZq1Z_NGwEnpxUYbSeSBI93XnFH_sgvQldmko1%40thread.tacv2/conversations?groupId=47b7-8c4e-ac6d3fad8315&tenantid=c8007caa-6ac0-4831-ae76-2406be3da013

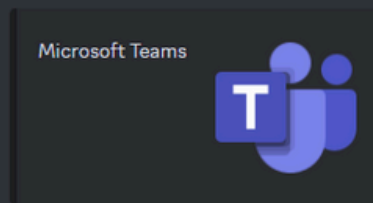

petah připnul/a zprávu do tohoto kanálu. Zobrazit všechny připnuté zprávy. 28.11.2024 20:04



WholsLag 27.09.2023 9:54

Druhy programů podle použití

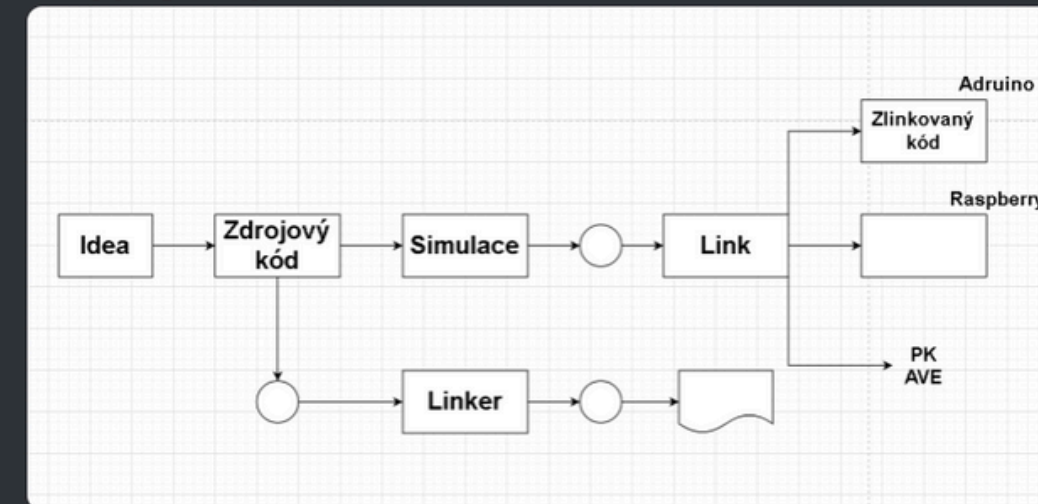

WholsLag 27.09.2023 10:27

Software

Software

- Operační systémy.
- Aplikace: Word.
- Program: .exe, .bat, .com, .hex, .bin.
- Knihovny, skripty: .js, .dll, .shv.
- Data:
 1. Video: mp4, mkv, avi.
 2. Audio: mp3, raw, flac.

Onfine

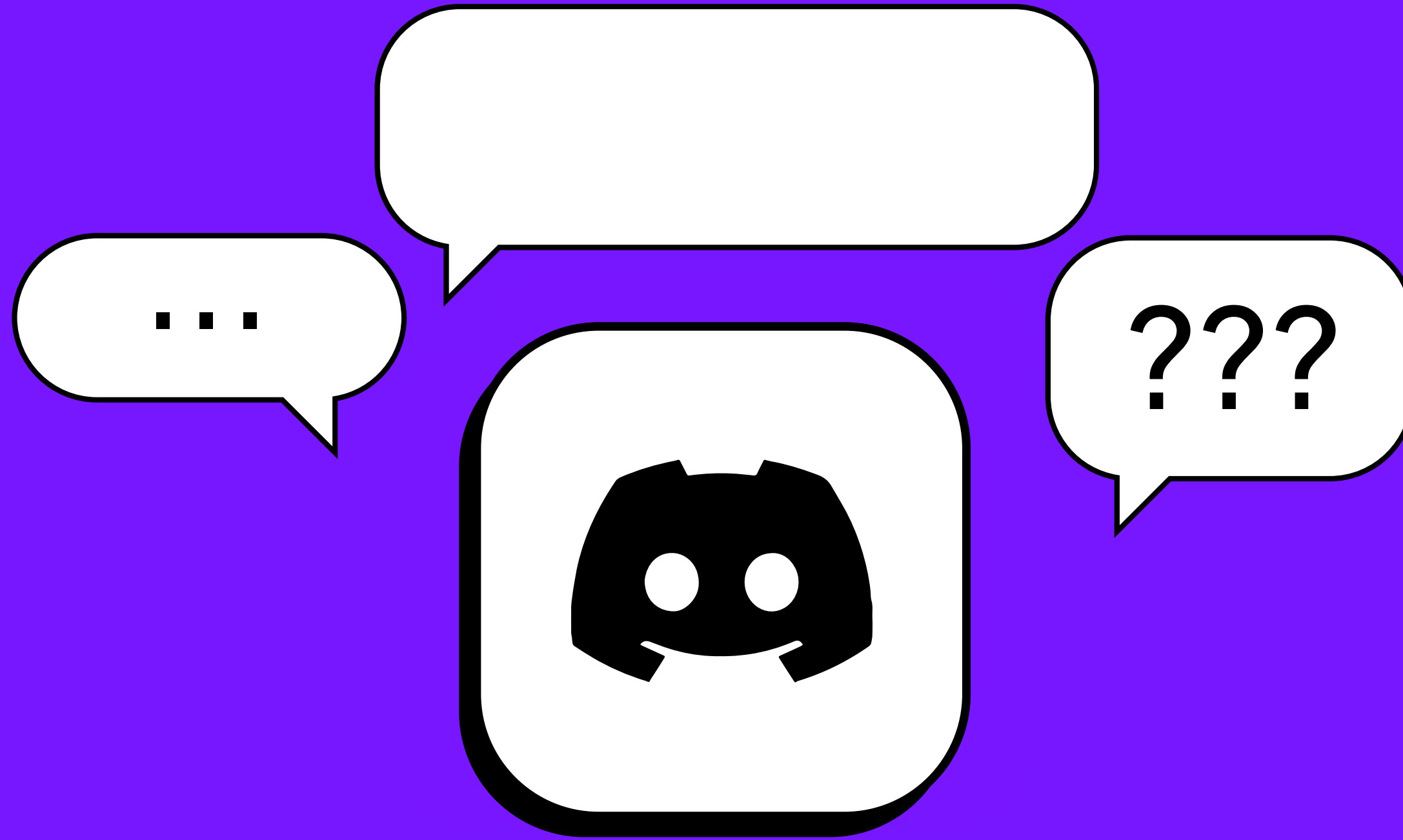

Discord

Online



TikTok

Online



TikTok

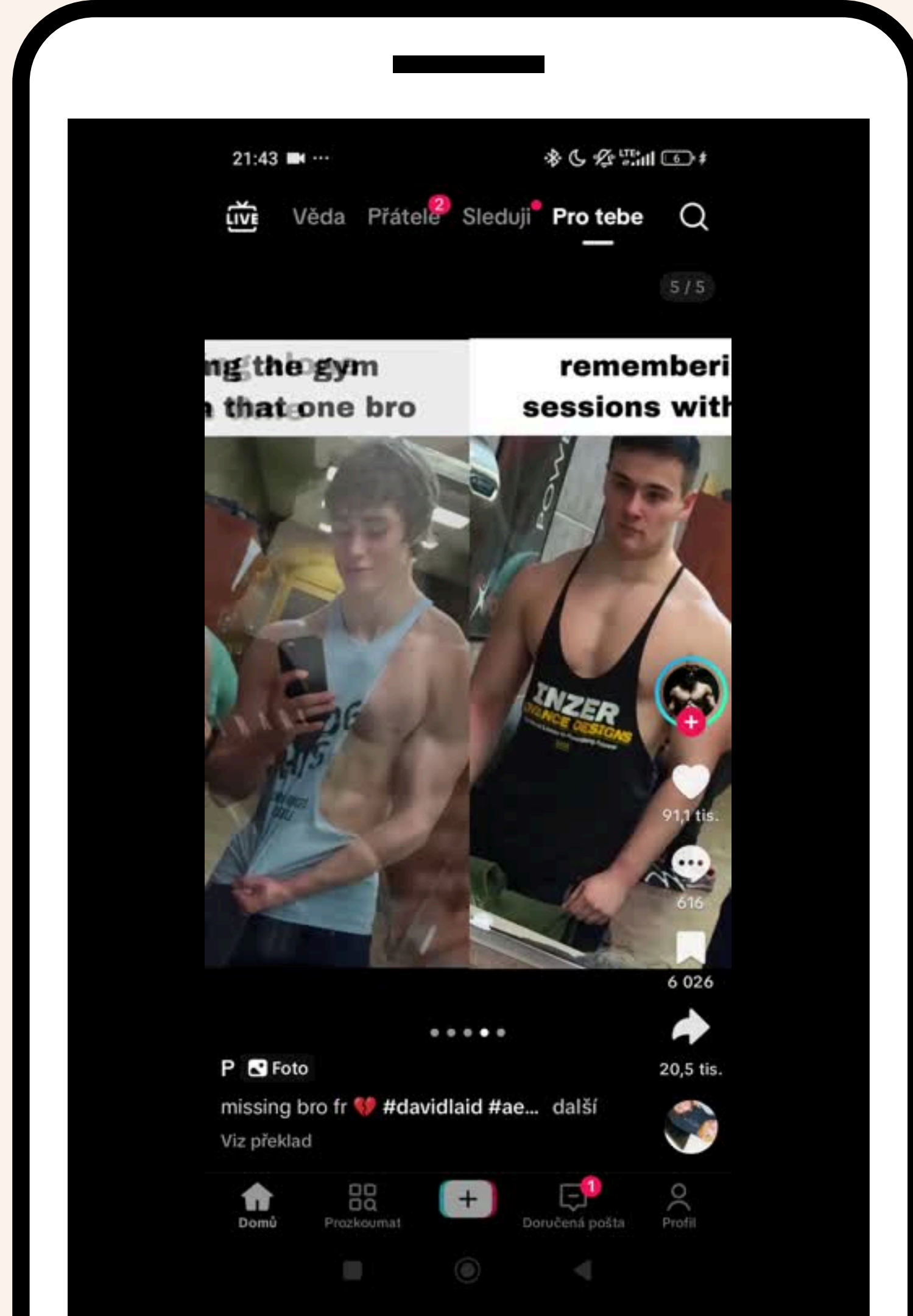

Online



TikTok

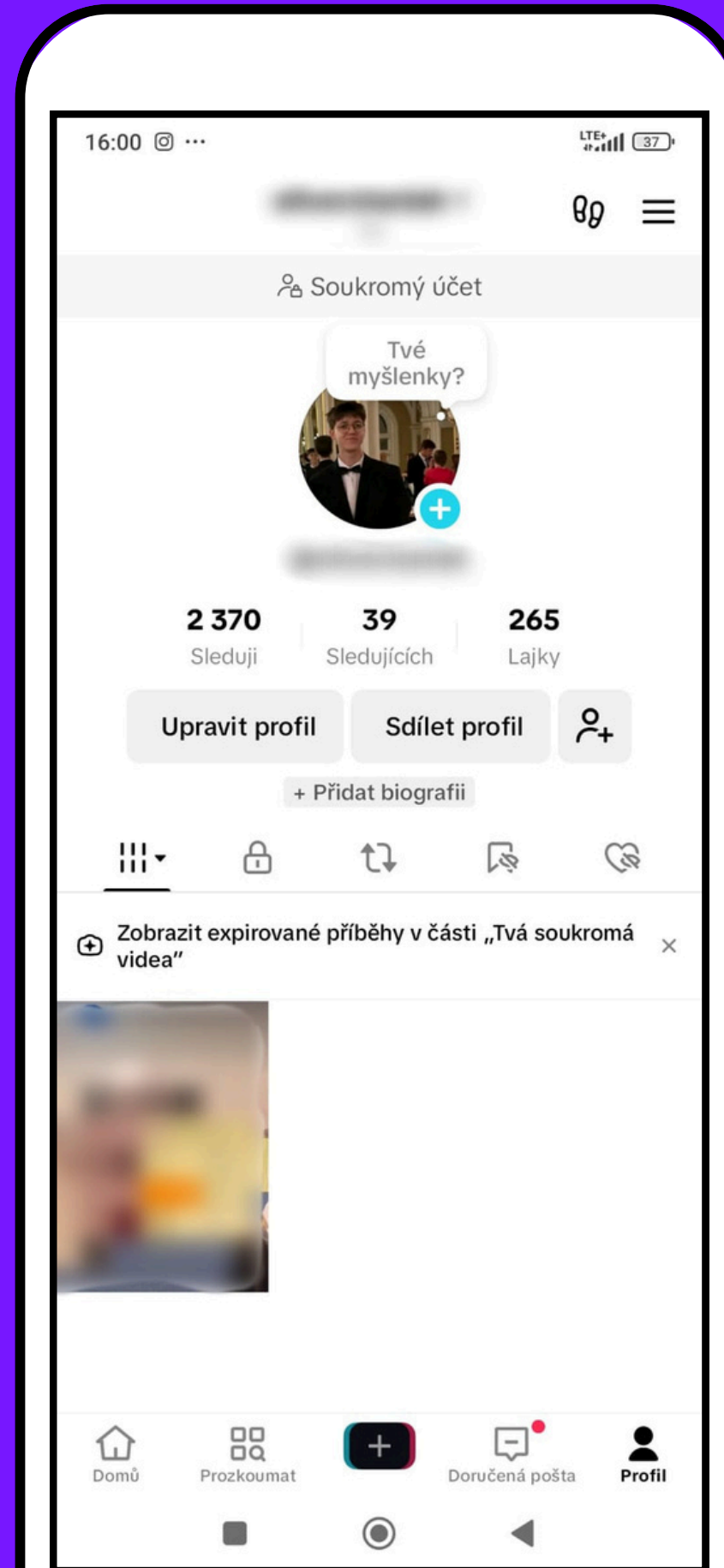
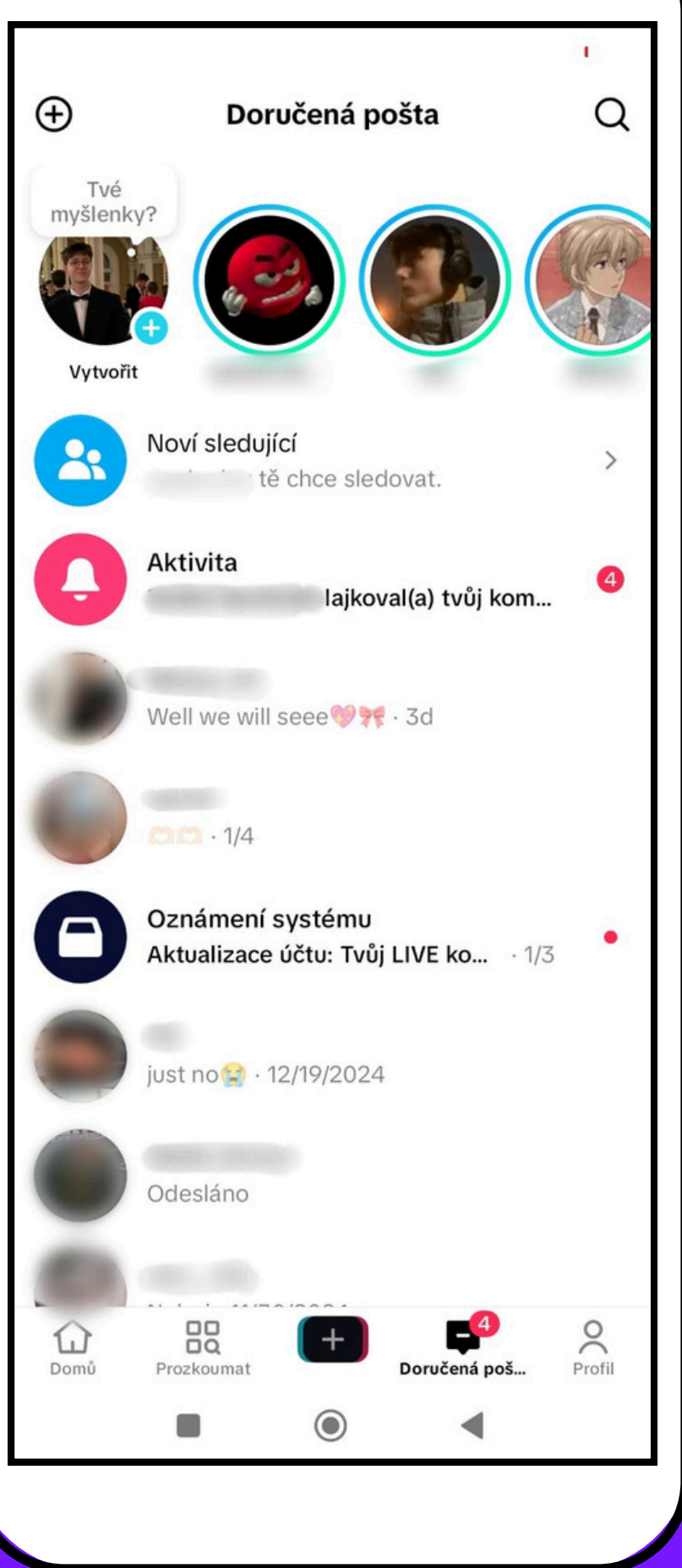

Onfine



Online

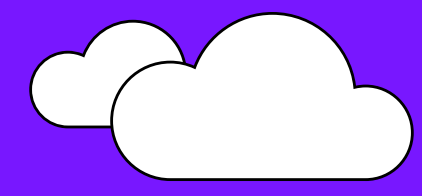

ÚVOD

ZNÁTE
VŠECHNY
SOCKY?

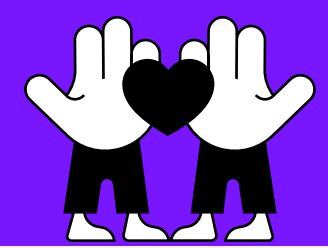

1

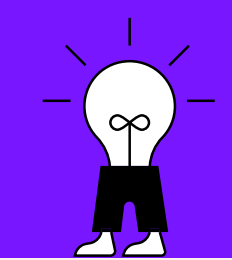

2



3

4



PONOR
DO SVĚTA
SOCIÁLNÍCH SÍTÍ

JAK NA ZDRAVÉ
UŽÍVÁNÍ

Onfine

NAŠE TIPY

- **povídejte si** doma, či ve školách o technologiích, uznejte i **pozitivní stránky**
- nemusíte znát všechny socky a trendy, **stačí se zajímat**
- sledujte **vlastní užívání**

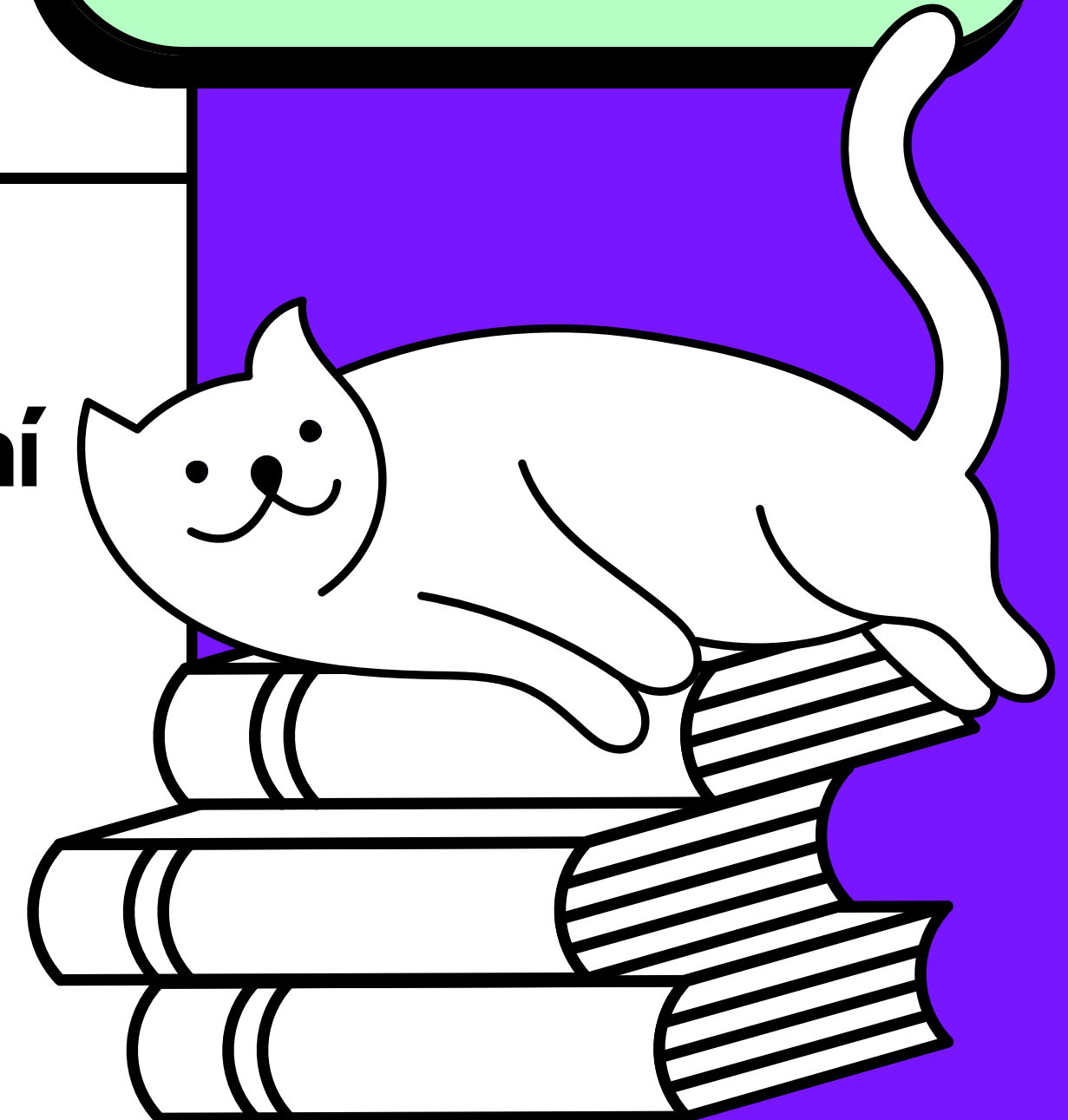

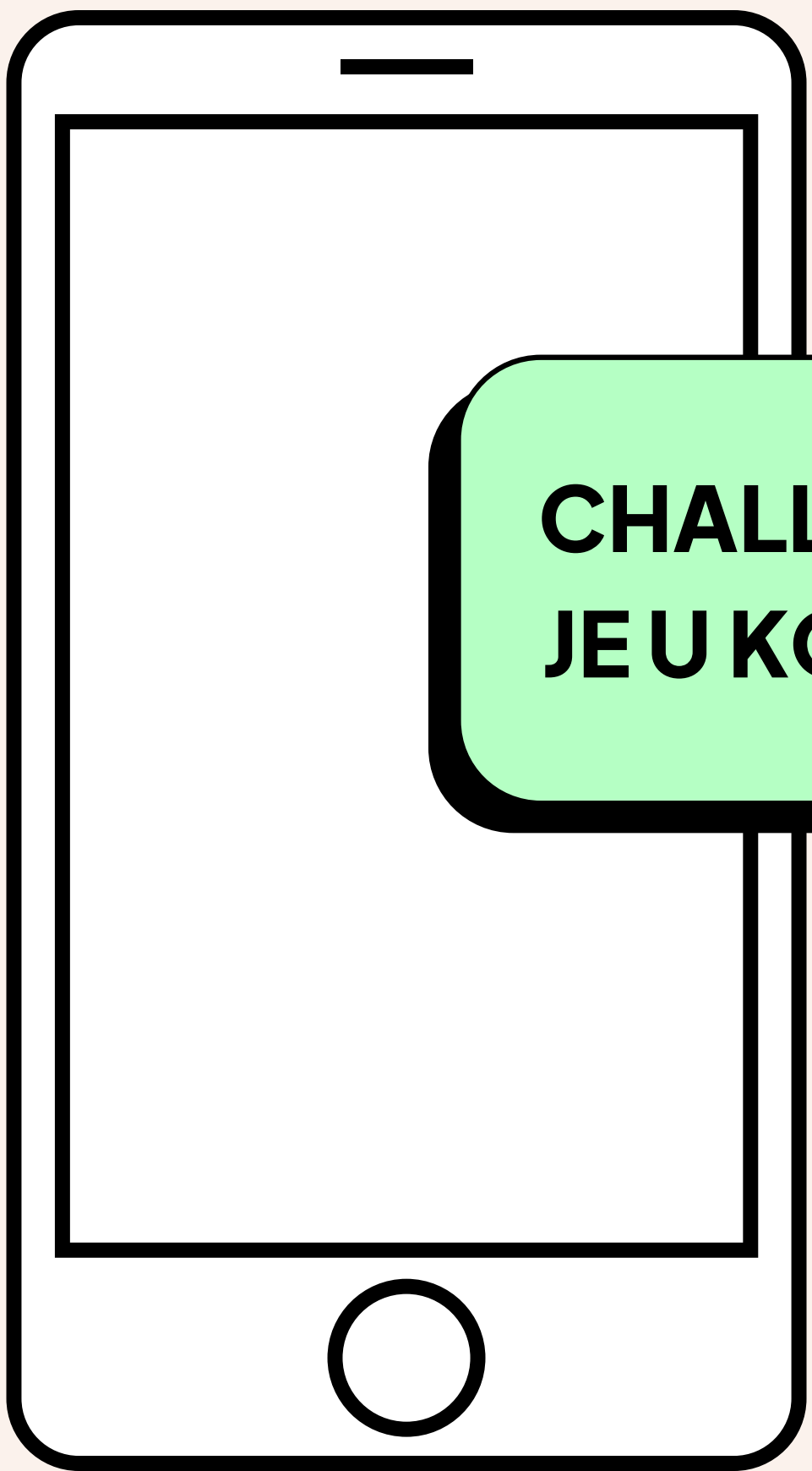

**CHALLENGE
JEU KONCE!**

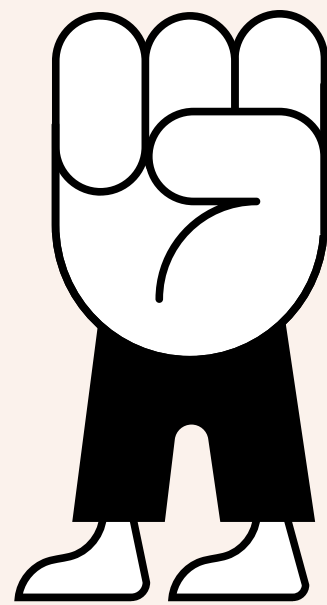

Online

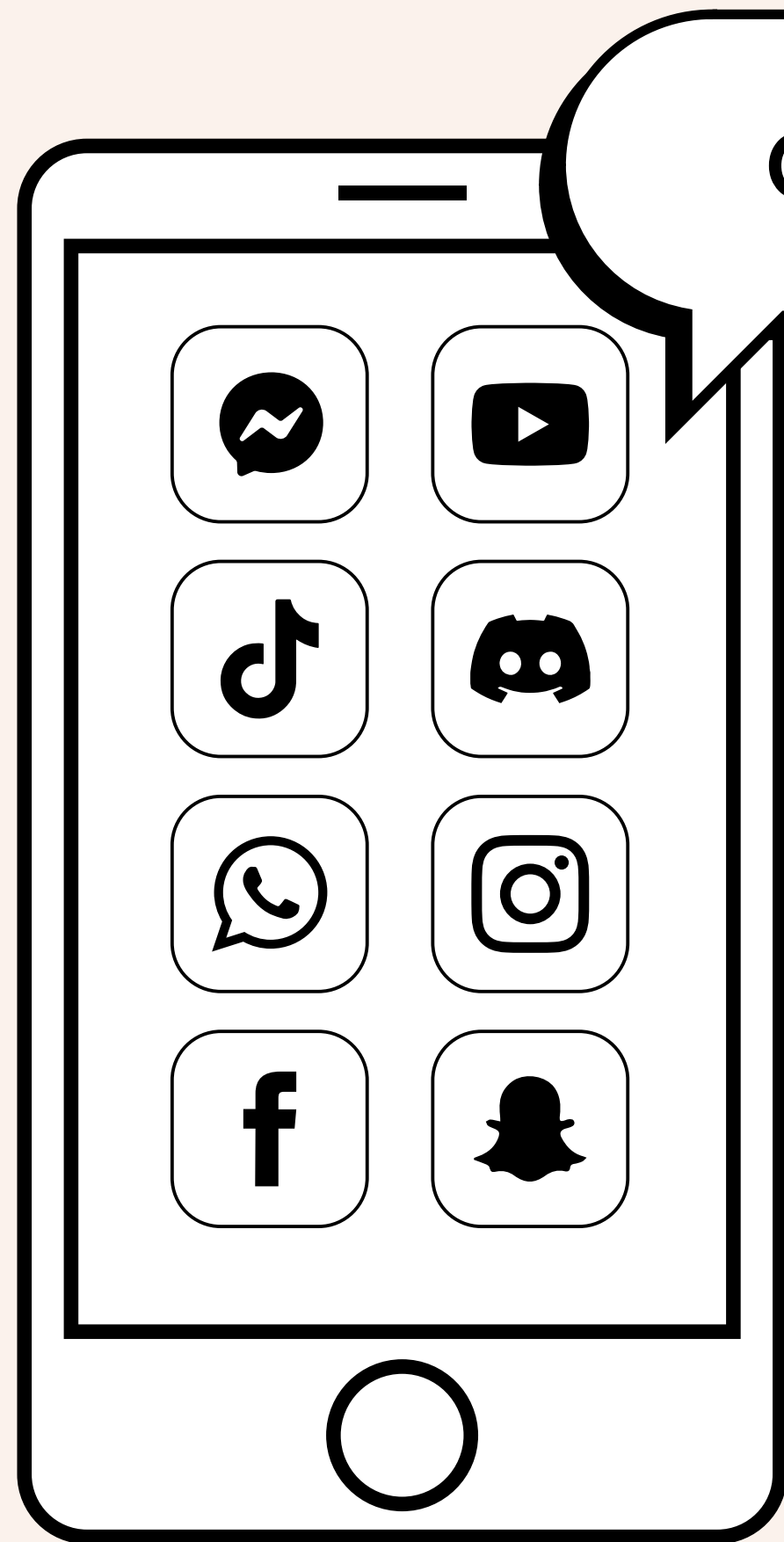

Chodím na ni rád*a

Štve mě

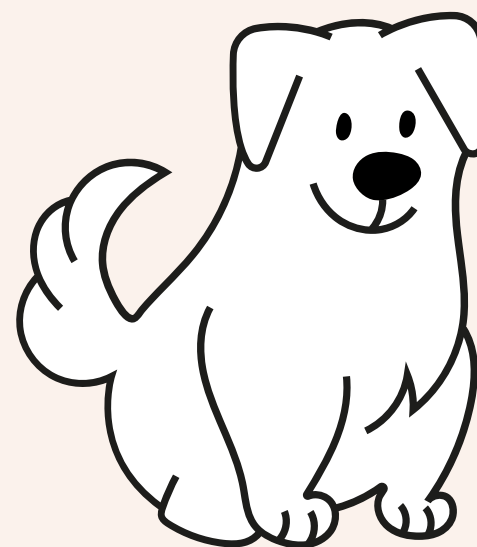

Online

Challenge!



www.onfine.cz/challenge

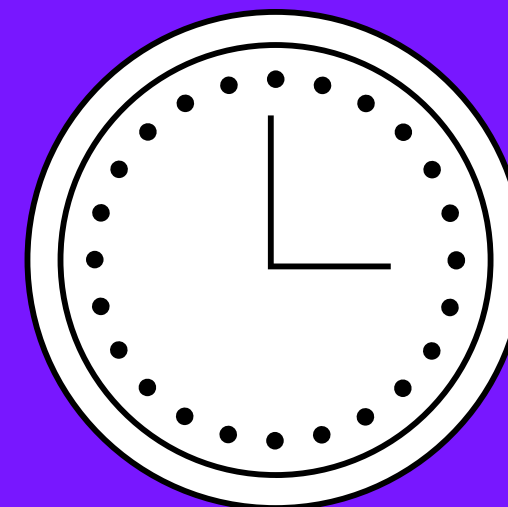

Přihlaste se k odběru
newsletteru

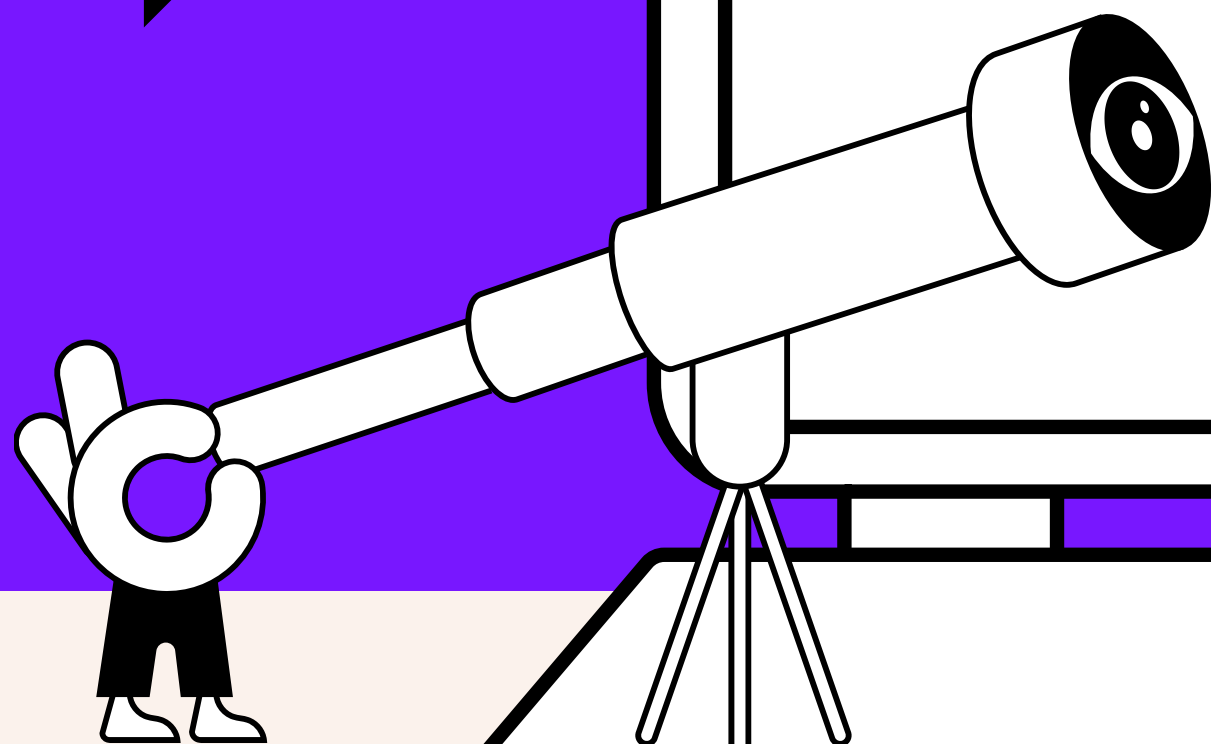
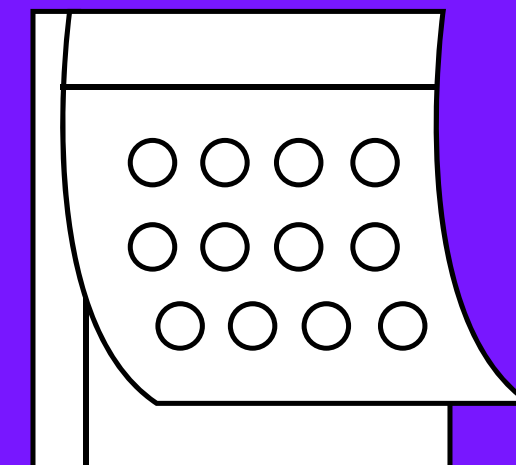

Online

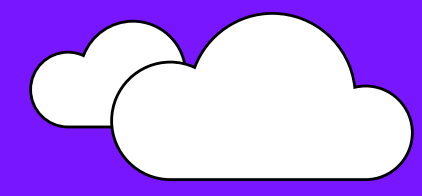

ÚVOD

ZNÁTE
VŠECHNY
SOCKY?

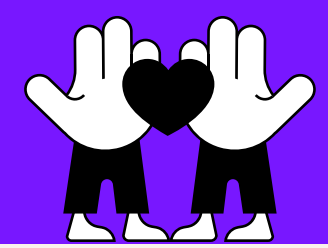

1

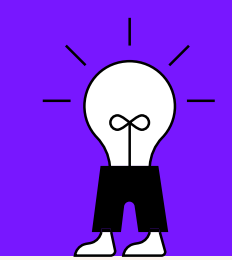

2



3

4



PONOR
DO SVĚTA
SOCIÁLNÍCH SÍTÍ

JAK NA ZDRAVÉ
UŽÍVÁNÍ

Online

Díky!

Onfine

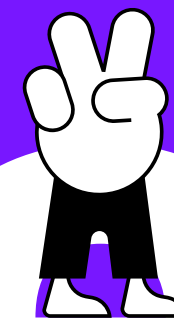

onfinecz

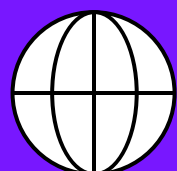

www.onfine.cz